



K6-Series PLC

User Manual

Revision History

Date	Revision	Description
2024/03/06	K6_usermanual_V000	Initial revision

Manual Acquisition

This manual is only available in PDF format. Users can log into the Kinco official website (<https://www.kinco.cn/>) and going to "Services -> Downloads" to search for keywords and download the document.

Programming Software Acquisition

- The K6 series PLC utilizes the KincoBuilder (compliant with the IEC 61131-3 standard) for programming and debugging, supporting both LD and IL programming languages. The software installation package for KincoBuilder can be obtained through the download service on the Kinco official website (<https://www.kinco.cn/download/plczzz18.html>).
- When using the K6 series, please use KincoBuilder V8.5.0.3 or a newer software version for programming and development.
- The latest version of KincoBuilder always maintains compatibility with the functionalities of the old versions, but new PLC instructions and features require the use of updated software and firmware versions. To ensure a smooth experience, please promptly download the latest version of the programming software.

Safety Precautions



This chapter explains the safety precautions that need to be followed when using this product. Before using the product, please read the product manual and any associated manuals referenced in it to correctly understand the relevant safety information. Failure to comply with the provisions of the safety precautions may result in death, serious injury, or equipment damage.

The "Danger," "Warning," and "Caution" items in the manual do not represent all safety precautions to be followed but serve as supplements to all safety precautions.

This product should be used in environments that meet the design specifications; otherwise, malfunctions may occur, and any abnormalities in function or component damage due to non-compliance with relevant regulations are not covered by the product quality guarantee.

Step Science will not be liable for any legal responsibility arising from personal safety accidents or property losses caused by non-compliance with the content of this manual or

To ensure the safe use of the product, this manual uses the following symbols and graphics to indicate precautions and highlights safety-related important content. Please be sure to comply.

	<p>Danger</p> <p>Indicates dangerous behavior. Failure to take appropriate precautions may result in serious personal injury or death.</p>
	<p>Warning</p> <p>Indicates warning behavior. Failure to take appropriate precautions may result in serious personal injury or death.</p>
	<p>Caution</p> <p>Indicates general information or instructional behavior. Failure to heed the corresponding prompts may lead to unforeseen consequences.</p>

When Power is Supplied



- ❖ During power supply, do not touch any terminals or terminal blocks, and do not attempt to disassemble any units. Especially during power supply or just after power is turned off, capacitors need time to discharge, which may cause electric shock or other personal or equipment hazards.

During Assembly



- ❖ Assembly, wiring, maintenance, and inspection of this product should all be conducted by professional personnel who have received relevant training in electrical equipment.
- ❖ Do not use PLCs in the following places: environments with dust, oil fumes, conductive dust, corrosive gases, or flammable gases; exposure to high temperatures, condensation, wind, or rain; environments with vibration or impact. Electric shock, fire, or misuse may also result in product damage.



- ❖ During screw assembly or wiring, be careful not to allow metal shavings, dust, or wire ends to fall into the ventilation holes of the PLC. Otherwise, it may cause fire, malfunction, or unintended actions of the PLC.

Wiring



- ❖ During power supply, do not touch any terminals or terminal blocks, and do not attempt to disassemble any units. Especially during power supply or just after power is turned off, capacitors need time to discharge, which may cause electric shock or other personal or equipment hazards.
- ❖ Before wiring operations, please ensure that all external power supplies to the system are completely disconnected. Otherwise, there is a risk of electric shock to personnel and equipment malfunction.



- ❖ After completing the installation and wiring operations, before energizing and operating the product, ensure that it is fully assembled (including end caps, plate covers, etc.), otherwise there may be a risk of electric shock.
- ❖ Cable terminals should be properly insulated to ensure that the insulation distance between cables does not decrease after the cables are installed on the terminal block. Otherwise, there is a risk of electric shock, short circuit, or equipment damage.



- ❖ During screw assembly or wiring, be careful not to allow metal shavings, dust, or wire ends to fall into the ventilation holes of the PLC. Otherwise, it may cause fire, malfunction, or unintended actions of the PLC.
- ❖ Before connecting relevant cable connections, confirm the type of interface to be connected. Incorrect wiring may lead to controller or external equipment malfunctions or damage.
- ❖ Tighten the bolts on the terminal block within the specified torque range. Loose terminal bolts may result in circuit shorts, disconnections, fires, and other hazards. Over-tightening the bolts may damage the bolts and the controller, leading to component detachment, circuit shorts, fires, and other hazards.

- ❖ When using connectors and connecting external devices, use the tools specified by the manufacturer for pressing, crimping, or correct soldering. Poor connections may lead to shorts, fires, and other hazards.
- ❖ Do not bundle control lines and communication cables with main circuit or power supply lines, or place them too close to each other. Control lines and communication cables should be arranged at least 100mm away from main circuit power lines in cable ducts or spaces to avoid interference due to electromagnetic noise.
- ❖ For applications with severe interference, use special shielded cables for high-frequency signal input or output to improve the system's anti-interference capability.

During System Design



- ❖ When applying, it is essential to design a safety circuit to ensure that the control system remains safe even in the event of a power failure or controller malfunction.
- ❖ If the output circuit experiences prolonged overcurrent due to exceeding the rated load current or load short circuits, the controller may smoke or catch fire. Therefore, external safety devices such as fuses or circuit breakers should be installed to interrupt power.



- ❖ It is crucial to set up emergency braking circuits, protection circuits, interlocking circuits for forward and reverse operations, and upper and lower limit interlock switches in the external circuits of the controller to prevent machine damage.
- ❖ To ensure safe equipment operation, design external protection circuits and safety mechanisms for significant accident-related output signals.
- ❖ When the controller's CPU detects abnormalities in its system, it may automatically shut off all output signals. Additionally, partial circuit failures in the controller may result in uncontrolled outputs. To ensure equipment's normal operation, suitable external control circuits need to be designed.
- ❖ Damage to the transistor output unit of the controller may render its output status uncontrollable.
- ❖ Programmable controllers should be designed for use in indoor electrical environments with overvoltage level II. The power supply system level should include lightning protection devices to prevent lightning-induced overvoltage from affecting the programmable controller's power input terminals, signal input terminals, control output terminals, and other ports, thus avoiding equipment damage.

During Operation and Maintenance



- ❖ Assembly, wiring, maintenance, and inspection of this product should all be conducted by professional personnel who have received relevant training in electrical equipment.
- ❖ Before cleaning or tightening the bolts on the terminal block or installing connector bolts, please ensure that the system's power supply is completely disconnected.



- ❖ Before making any online modifications to the program, forcing outputs, starting (RUN), or stopping (STOP) operations during equipment debugging, it is essential to thoroughly read the user manual. Only proceed with these operations after ensuring their safety.

Table of Contents

Revision History.....	II
Manual Acquisition.....	II
Programming Software Acquisition	II
Safety Precautions.....	III
1 Overview	1
1.1 Product Introduction	1
1.2 Product Information	1
1.2.1 Naming Rules.....	1
1.2.2 Labeling.....	2
1.3 Operating and Storage Conditions	3
1.4 Product List.....	5
2 Introduce to K6-series	7
2.1 Features	7
2.2 CPU Unit.....	9
2.2.1 K606 Components	9
2.2.2 K606EA/K608 Components	10
2.2.3 Functional Description.....	11
2.2.3.1 Status Display	11
2.2.3.2 BD Expansion	15
2.2.3.3 EtherNET	17
2.2.3.4 Expansion Interface	18
2.2.3.5 Data Maintain & Permanent Storage	18
2.2.3.6 Real-time Clock.....	20
2.2.3.7 High-speed Inputs.....	22
2.2.3.8 High-speed Outputs	23
2.2.3.9 External Interruption	24
2.2.3.10 Integrated Power Supply.....	24
2.2.3.11 RS485	25
2.2.4 Specifications	25
2.2.4.1 Power Supply.....	25
2.2.4.2 DI	26
2.2.4.3 DO(Transistor)	26
2.2.4.4 DO(Relay).....	27
2.2.4.5 AI.....	27

2.2.4.6 AO.....	27
2.2.4.7 Communication Interface.....	28
2.2.4.8 Storage & RTC.....	28
2.2.4.9 BD Expansion Modules.....	29
2.3 Expansion Modules.....	31
2.3.1 Components.....	31
2.3.2 Specifications.....	32
2.3.2.1 K621-08DX.....	32
2.3.2.2 K621-16DX.....	33
2.3.2.3 K622-08DT.....	34
2.3.2.4 K622-08XR.....	35
2.3.2.5 K622-16DT.....	36
2.3.2.6 K622-16XR.....	37
2.3.2.7 K623-08DT.....	38
2.3.2.8 K623-08DR.....	39
2.3.2.9 K623-16DT.....	40
2.3.2.10 K623-16DR.....	41
2.3.2.11 K631-04IV.....	42
2.3.2.12 K631-04TC.....	43
2.3.2.13 K631-04RD.....	45
2.3.2.14 K632-02IV.....	46
2.3.2.15 K633-04IV.....	48
2.3.2.16 K680.....	2
3 Wiring Instructions.....	3
3.1 CPU Unit.....	3
3.1.1 RS485.....	3
3.1.2 EtherNET.....	4
3.1.3 Power Supply.....	5
3.1.4 I/O.....	6
3.1.4.1 DI.....	6
3.1.4.2 DO(Transistor).....	6
3.1.4.3 DO(Relay).....	7
3.1.4.4 AI.....	7
3.1.4.5 AO.....	8
3.1.5 Wiring Diagrams.....	9

3.1.5.1 CPU K606	9
3.1.5.2 CPU K608	11
3.1.5.3 CPU K606EA	13
3.2 BD Expansion	14
3.2.1 KB6-CAN	14
3.2.2 KB6-2COM	15
3.2.3 KB6-4DI	16
3.2.4 KB6-4DO	16
3.2.5 Wiring Diagram	17
3.3 Expansion Modules	18
3.3.1 K621-08DX	18
2.3.3 K621-16DX	20
2.3.4 K622-08DT	22
2.3.5 K622-08XR	24
2.3.6 K622-16DT	26
2.3.7 K622-16XR	28
2.3.8 K623-08DT	30
2.3.9 K623-08DR	32
2.3.10 K623-16DT	34
2.3.11 K623-16DR	36
2.3.12 K631-04IV	39
2.3.13 K631-04TC	42
2.3.14 K631-04RD	45
2.3.15 K632-02IV	47
2.3.16 K633-04IV	49
2.3.17 K680	52
4 Dimension	53
4.1 CPU Unit	53
4.1.1 CPU K606	53
4.1.2 CPU K606EA/K608	54
4.2 Expansion Modules	55
4.2.1 K621-08DX/K621-16DX/K622-08DT/K622-08XR/K622-16DT/K622-16XR/K62	
3-08DT/K623-08DR/K623-16DT/K623-16DR/K680	55
4.2.2 K631-04IV/K631-04TC/K631-04RD/K632-02IV/K633-04IV	56
5 Assembly Guidelines	57

5.1 Connection of CPU and Modules	57
5.2 Assembly of BD Expansion Module.....	58
5.3 Dis/Assembly of Terminal Blocks.....	58
5.3.1 Disassembly of the Terminal Blocks.....	58
5.3.2 Assembly of Terminal Blocks.....	58
5.4 Mounting Guidelines.....	60
5.4.1 Mounting with DIN Rail.....	60
5.4.1.1 Standards of Din Rail	60
5.4.1.2 Mounting/Dismounting.....	60
5.2.4 Mounting with M4 Screws	63
6 Getting Started.....	65
6.1 Introduce of Interface.....	65
6.2 Create a New Project.....	66
6.3 Hardware Configuration	67
6.3.1 Configure the CPU	67
6.3.2 Configure the Expansion Modules	70
6.3.3 Configure the BD Modules	71
6.4 Programming Simplified Guide.....	73
6.4.1 On-line Help	73
6.4.2 Programming Languages.....	74
6.4.3 Programming Instructions	74
6.5 Compiler and Simulator.....	75
6.5.1 Compiler.....	75
6.5.2 Simulator	76
6.6 PLC Connection and Program Up/Download.....	79
6.6.1 Communication between PC and K6-series PLC.....	79
6.6.2 Program Upload/Download.....	84
6.7 Error Message and Solution	87
6.7.1 Error Message in KincoBulider.....	87
6.7.2 Common Error.....	87
6.8 Firmware Update.....	88
7 Services and Support.....	92
7.1 Services.....	92
7.2 Contact Us.....	92
8 Appendix.....	93

8.1 Fast Selection List	93
8.2 Output Power Supply.....	95
8.3 Expansion-bus Power Consumption Calculation	95
8.4 Input Power for the CPU.....	96
8.5 Example of PLC System Selection&Power Calculation	98
8.5.1 General Guidelines for PLC System Selection.....	98
8.5.2 Example of System Selection.....	98

1 Overview

1.1 Product Introduction

The Kinco-K6 series is a high-performance compact PLC introduced by Kinco company. It adopts a brand-new technological platform and provides functionalities such as Ethernet, CAN bus, and expansion board interfaces that are more closely aligned with user needs, while ensuring high performance and reliability. With significantly faster operation speed, larger storage space, and significantly improved functionalities, it can meet a diverse range of user needs.

1.2 Product Information

1.2.1 Naming Rules

The naming rules for product models are as follows:

Module Type + Number of Channels + Function identification, as shown in Figure 1.2-1.

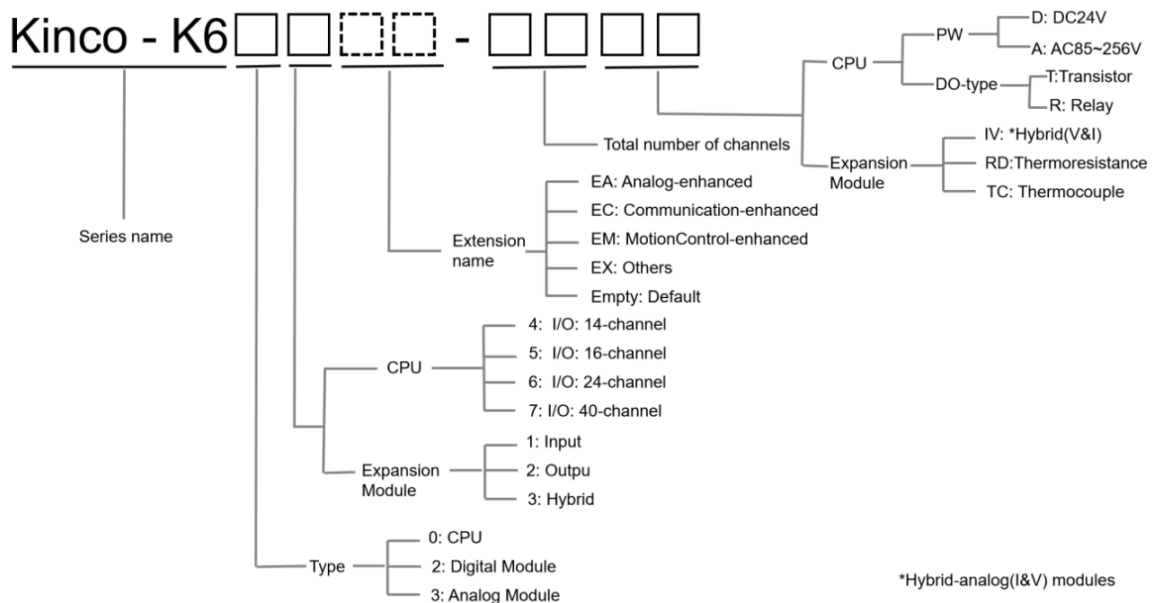

According to the rule:

K606-24DT represents a CPU module with 24V DC power supply and 24 I/O channels.

K622-16DT represents an output expansion module with 24V DC power supply and 16 I/O channels.

1.2.2 Labeling

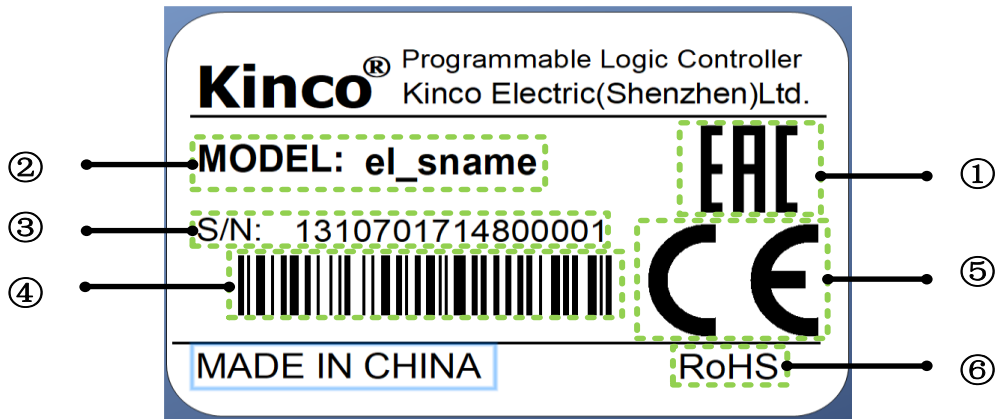

No.	Description
①	EAC Certification
②	Model
③	The first 1~6 codes represent a product code, which ensures uniqueness for different models.
	The 7th~8th codes indicate the production year, indicating the year of production (e.g., "2017" for 2017) .
	The 9th~11th codes represent the production day, indicating the day of production within the year (e.g., "148" for the 148th day of the year).
	The 12th~16th codes indicate the production sequence of the product on that particular day, indicating the sequential order of production for products of the same model on that day (e.g., "001" for the first product).
④	Product Serial Number Barcode
⑤	CE Certification
⑥	RoHS Certification

1.3 Operating and Storage Conditions

The K6 series products complies with the GB/T 15969.3-2007 (equivalent to IEC61131-2:2007) standard and testing specifications.

Transportation and Storage		
Environmental Conditions	Temperature	-40°C ~ +70°C
	Relative Humidity	10% ~ 95%, non-condensing
	Atmospheric Pressure	Altitude of 0 ~ 3000 meters above sea level
Mechanical Conditions	Free Fall	With transportation packaging, allowed to fall 5 times from a height of 1 meter onto a cement surface.
Operating Conditions		
Environmental Conditions	Temperature	Naturally ventilated open device, -10 ~ 55°C
	Relative Humidity	10% ~ 95%, non-condensing
	Atmospheric Pressure	Altitude not exceeding 2000 meters
	Pollution Level	Level 2
Mechanical Conditions	Sinusoidal Vibration	5 < f < 8.4Hz: Random Vibration Displacement: 3.5mm Continuous Vibration Displacement: 1.75mm 8.4 < f < 150Hz: Random Vibration Acceleration: 1.0g Continuous Vibration Acceleration: 0.5g
	Shock	Half-sine wave, 15g, 11ms, six times per axis
Electromagnetic Compatibility (EMC)	Electrostatic Discharge	Air Discharge: 8KV Withstands Contact Discharge: 4KV Withstands Level B
	Surge	AC power supply: 2KV CM, 1KV DM DC power supply: 0.5KV CM, 0.5KV DM IO and Communication Interfaces: 1KVCM Level B

	EFT (Electrical Fast Transient)	Power supply coupling: 2KV, 5KHz IO and communication coupling: 1KV, 5KHz Level B
	Voltage Dip	AC system, at 50Hz, voltage drop to 0% for 1 cycle, 40% for 10 cycles, 75% for 20 cycles. Level A
Ingress Protection	Waterproof and Dustproof	IP20

1.4 Product List

*High-speed output function is not supported by relay output CPU modules whose last code digit is "R".

Model	Description
CPU	
K606-24DT	Powered by DC 24V, DI 14*DC24V(PNP/NPN), DO 10*DC24V(PNP) 2*RS485, 1*Ethernet Support a maximum of 1 BD expansion module and 14 bus-expansion modules.
K606-24AT	Powered by AC100-240V, DI 14*DC24V(PNP/NPN), DO 10*DC24V(PNP) 2*RS485, 1*Ethernet Support a maximum of 1 BD expansion module and 14 bus-expansion modules.
K606-24DR	Powered by DC24V, DI 14*DC24V(PNP/NPN), DO 10*Relay 2*RS485, 1*Ethernet Support a maximum of 1 BD expansion module and 14 bus-expansion modules.
K606-24AR	Powered by AC100-240V, DI 14*DC24V(PNP/NPN), DO 10*Relay 2*RS485, 1*Ethernet Support a maximum of 1 BD expansion module and 14 bus-expansion modules.
K606EA-30DT	Powered by DC24V, DI 14*DC24V(PNP/NPN), DO 10*DC24V(PNP), AI 4*IV, AO 2*IV 2*RS485, 1*Ethernet Support a maximum of 2 BD expansion modules and 14 bus-expansion modules.
K606EA-30AT	Powered by AC100-240V, DI 14*DC24V(PNP/NPN), DO 10*DC24V(PNP); AI 4*IV, AO 2*IV 2*RS485, 1*Ethernet Support a maximum of 2 BD expansion modules and 14 bus-expansion modules.
K608-40DT	Powered by DC24V, DI 24*DC24V(PNP/NPN), DO 16*DC24V(PNP) 2*RS485, 1*Ethernet Support a maximum of 2 BD expansion modules and 14 bus-expansion modules.
K608-40AT	Powered by AC100-240V, DI 24*DC24V(PNP/NPN), DO 16*DC24V(PNP) 2*RS485, 1*Ethernet Support a maximum of 2 BD expansion modules and 14 bus-expansion modules.
K608-40DR	Powered by DC24V, DI 24*DC24V(PNP/NPN), DO 16*Relay 2*RS485, 1*Ethernet Support a maximum of 2 BD expansion modules and 14 bus-expansion modules.

K608-40AR	Powered by AC100-240V, DI 24*DC24V(PNP/NPN), DO 16*Relay 2*RS485, 1*Ethernet Support a maximum of 2 BD expansion modules and 14 bus-expansion modules.
Expansion Modules	
K621-08DX	DI 8*DC24V (PNP/NPN)
K621-16DX	DI 16*DC24V (PNP/NPN)
K622-08XR	DO 8*Relay
K622-16XR	DO 16*Relay
K622-08DT	DO 8*DC24V(PNP)
K622-16DT	DO 16*DC24V(PNP)
K623-16DR	DI 8*DC24V(PNP/NPN), DO 8*Relay
K623-08DR	DI 4*DC24V(PNP/NPN), DO 4*Relay
K623-16DT	DI 8*DC24V(PNP/NPN), DO 8*DC24V(PNP)
K623-08DT	DI 4*DC24V(PNP/NPN), DO 4*DC24V(PNP)
K631-04IV	4*AI, 4-20mA/1-5V/0-20mA/0-10V
K631-04RD	4*RD, Pt100, Pt1000, Cu50, Resistor
K631-04TC	4*TC, thermocouple cold junction compensation (CJC) options include internal and external compensation. Supported thermocouple types include J, K, E, S, and T.
K632-02IV	2*AO, 4-20mA/1-5V/0-20mA/0-10V
K633-04IV	2*AI, 4-20mA/1-5V/0-20mA/0-10V 2*AO, 4-20mA/1-5V/0-20mA/0-10V
BD Expansion Module	
KB6-CAN	1*CAN(CAN2)
KB6-2COM	1*RS232(PORT0), 1*RS485(PORT3)
KB6-4DI	DI 4*DC24V(PNP/NPN)
KB6-4DO	DO 4*DC24V(PNP)
Power Supply Module	
K680	Powered by AC85~265V; Rated output current: 5V 1A/24V 250mA

2 Introduce to K6-series

2.1 Features

- Adopts a brand-new MCU platform with faster processing speed, where the scanning cycle for 1000 commonly used instructions is 0.3ms. It provides 8k instructions of program storage and 20k bytes (V area + M area) of data storage , ensuring the implementation of complex control programs.

- The CPU supports optional DC/AC power supplies and various IO combinations; supports the configuration of multiple expansion modules, covering functions such as DI/O, AI/O, temperature detection, etc. The K6 series CPU can support up to 14 expansion modules at most, allowing users to freely select and configure them to create control systems suitable for various scenarios.

- Supports expansion BD boards (Basic Unit Expansion Boards), which provide sufficient IO channels or communication. With an embedded onboard design, compared to expansion modules, BD boards have lower expansion costs, helping users adapt to more application scenarios.

- Supports array functions, with support for up to 16 arrays, each allowing a maximum of 1024 elements (data type supported by K series PLC). Users can utilize array functions for functions such as finding maximum, minimum, average, sorting, etc., or further expand data storage space.

- Supports stack functions, with support for up to 2 stacks, each allowing a maximum of 1024 elements (data type supported by K series PLC). Users can utilize stack functions to meet corresponding requirements or further expand data storage space using stacks.

- The K6-series CPU supports expanding CAN communication through the BD board, which supports CANopen master function, allowing a maximum of 64 slave connections, with each slave allowing a maximum configuration of 8 TPDOs and 8 RPDOs. It supports node protection, heartbeat, and other error control methods. It also supports Kinco motion control protocol, with KincoBuilder providing motion control function wizards for quick connection to

Kinco servos.

- The K6 series CPU supports up to 4 channels of high-speed input, supporting various counting modes. Among them, the maximum counting frequency for HSC0 and HSC1 is 200kHz, and for HSC2 and HSC3, it is 20kHz(single-phase mode) and 10kHz(two-phase mode), respectively.
- The K6 series CPU supports up to 4 channels of high-speed output, with channels 0 to 2 supporting a maximum output frequency of 200kHz, and channel 3 supporting a maximum output frequency of 10kHz. All channels support PTO (pulse train output, pulse + direction) and PWM (pulse width modulation) output modes. The KincoBuilder also provides PLS (PWM or PTO), positioning control instruction sets, PFLO_F (follow instruction), etc., making it easy for users to implement simple motion control.
- The CPU comes standard with a 10/100M adaptive Ethernet port, supporting Modbus TCP Client/Server industrial bus protocols, with free transmission for TCP Client/TCP server and UDP peer, making it simple, easy to use, and powerful.
- KincoBuilder provides convenient and easy-to-use motion control instructions. The software is equipped with motion control wizards to help users get started with zero thresholds, quick configuration, and efficient programming.

2.2 CPU Unit

2.2.1 K606 Components

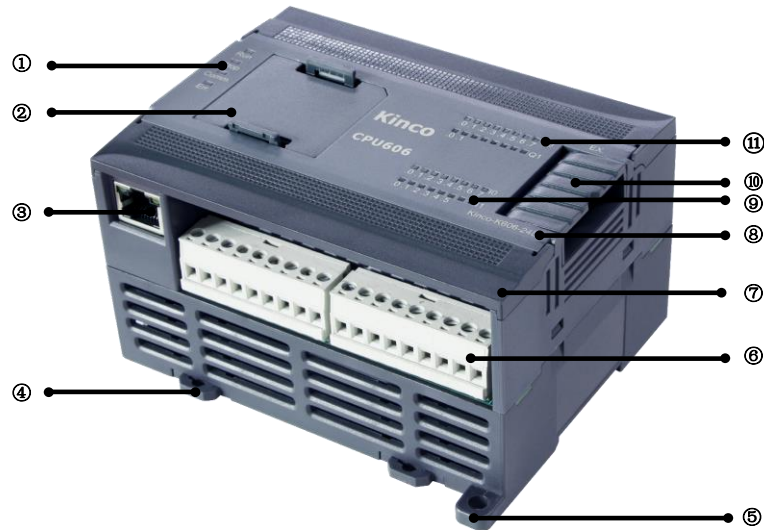

No.	Item	Function
①	Status Indicators	For displaying the current CPU status.
②	BD0(expansion board)	For expansion of the BD board, with cover plate as default.
③	EtherNET	For Ethernet communication.
④	Rail Card Slot Slider (35mm)	For mounting on DIN rail.
⑤	Bolt Mounting Hole(M4)	Can be reinforced with M4 bolts.
⑥	Screw-fastening Terminals	For wiring of inputs and outputs with screws and terminals are removable .
⑦	Terminal Cover	Prevents substances from dripping or splashing on the terminal screws, flip up the cover to see the channel labeling.
⑧	Model	For checking the current PLC model.
⑨	Input Indicators	Displays the on/off status of each channel of DI. Illumination of digital channels indicates they are on, while off indicates they are off. Illumination of analog channels indicates input exceeds the limit.
⑩	Expansion Interface	Used for connecting expansion modules.
⑪	Output Indicators	Displays the on/off status of each channel of DO. Illumination of digital channels indicates they are on, while off indicates they are off. Illumination of analog channels indicates output exceeds the limit.

2.2.2 K606EA/K608 Components

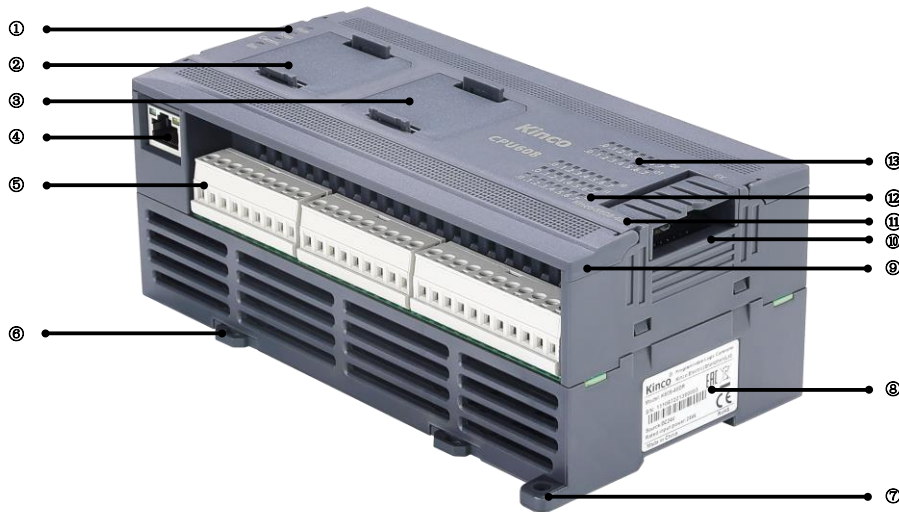

No.	Item	Function
①	Status Indicators	For displaying the current CPU status.
②	BD0(expansion board)	For expansion of the BD board, with cover plate as default.
③	BD1(expansion board)	For expansion of the BD board, with cover plate as default.
④	EtherNET	For Ethernet communication.
⑤	Screw-fastening Terminals	For wiring of inputs and outputs with screws and terminals are removable.
⑥	Rail Card Slot Slider (35mm)	For mounting on DIN rail.
⑦	Bolt Mounting Hole(M4)	Can be reinforced with M4 bolts.
⑧	Product Label	Display product model number, serial number and other information.
⑨	Terminal Cover	Prevents substances from dripping or splashing on the terminal screws, flip up the cover to see the channel labeling.
⑩	Expansion Interface	Used for connecting expansion modules.
⑪	Model	For checking the current PLC model.
⑫	Input Indicators	Displays the on/off status of each channel of DI. Illumination of digital channels indicates they are on, while off indicates they are off. Illumination of analog channels indicates input exceeds the limit.
⑬	Output Indicators	Displays the on/off status of each channel of DO. Illumination of digital channels indicates they are on, while off indicates they are off. Illumination of analog channels indicates output exceeds the

	limit.
--	--------

*The CPU K606EA and K608 only differ in the number and type of IO channels, with all other components being identical. The above diagram illustrates the components using the K608 as an example.

2.2.3 Functional Description

2.2.3.1 Status Display

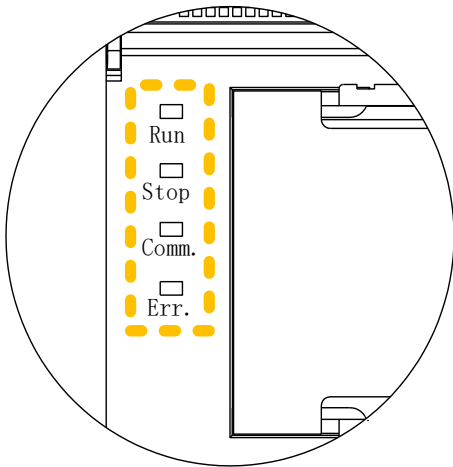

[Run]: PLC operating status indicator light. It lights up (green) during normal operation.

[Stop]: PLC stop status indicator light. It lights up (red) when the CPU is in a stopped state.

[Comm.]: PLC communication status indicator light. It blinks (green) when any communication port (PORT1/PORT2) is in the receiving or sending mode, or in other communication states.

[Err.]: PLC error indicator light. It lights up (red) when a user program or the CPU itself detects an error.

- CPU Indicator Lights

On the front panel of the K6 series PLC, there are four indicator lights, named Run, Stop, Comm., and Err., which are used to indicate the current operating status of the CPU.

The following table lists the behavior of the running CPU indicator and related descriptions:

Indicator	Color	Behavior	Description
Run	Gray (Off)/Green (On)	Always On	In running state
		Blink	In firmware updating mode
		Off	PLC is not running.
Stop	Gray (Off)/Red (On)	Always On	In stopped state
		Off	PLC is not stopping.
Comm.	Gray (Off)/Green (On)	Blink	Any communication port is working.
		Off	No communication
Err.	Gray (Off)/Red (On)	Always On	An error occurs in the user program or in the CPU, and the user can view the specific error through the KincoBuilder.
		Off	No error

The CPU categorizes errors into three levels: fatal errors, serious errors, and general errors. When the CPU detects an error, the Err lamp will be lit, and the CPU will store the specific error code according to the order of occurrence. Users can view the specific error information through the KincoBuilder programming software for further analysis. Please refer to [6.7 Error Message and Solution](#) for specific fault description analysis.

Type	Run	Stop	Err.	Description
Fatal Error	Off	Always On	Blinks	<p>When a fatal error occurs, the PLC exits the normal scanning state immediately and determines whether to reset the PLC directly or enter the independent safety subsystem operation according to the value of special register SM2.0:</p> <ul style="list-style-type: none"> -SM2.0 = 0, the PLC will enter the independent safety subsystem operation after a fatal error. -SM2.0 = 1, the PLC will reset and restart directly after a fatal error. <p>The default value of special register SM2.0 is 0 after power-up.</p> <p>*When the PLC enters the safe subsystem state, it may cause communication interruption and render it unusable. You can restore it to normal operation by selecting [Tools] in the menu bar, and then triggering the [Clear (for fatal errors only)] function in the drop-down menu to clear fatal errors in the PLC.</p>
Series Error	Off	Always On	Always On	A serious error in the PLC will result in the inability to continue to run the user program correctly, but the result is predictable.
General Error	Always On	Off	Always On	A normal error is an error in the execution of a function by the PLC, but it is possible to continue running other parts of the program with predictable results.

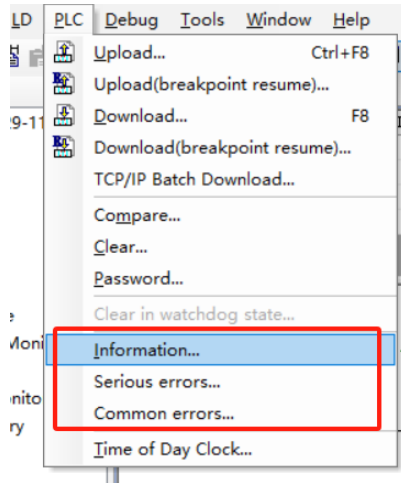

The CPU has two operation states: running and stopped. In the running state, the CPU executes the main tasks and various interrupt tasks in a normal loop scanning. In the stopped state, the CPU module only processes partial communication requests (including programming and debugging commands from KincoBuilder, as well as communication commands responding to the master station as a Modbus RTU slave), while immediately outputting the "Output State while Stop" values defined in the [hardware] of the project for all output points (DO).

- Change State of CPU

1. By KincoBuilder

- Connect the CPU with PC.(referring to [6.3.1 Configure the CPU](#) and [6.6.1 Communication between PC and K6-series PLC](#)).
- In KincoBuilder, execute the [Debug] → [Start PLC...] or [Stop PLC...] menu commands from the menu bar, as shown in the following image.

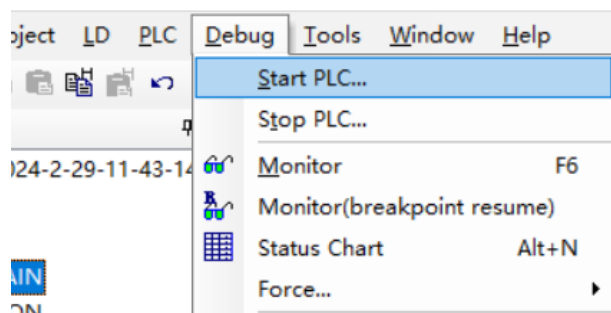

- 2.By DIP Switches

You can change the CPU state by the DIP switches. Move the DIP switch to the side labeled "RUN" to put the CPU into the running state. Move it to the side labeled "STOP" to put the CPU into the stopped state.

The DIP switches are located within the BD board expansion slot. To access them, remove

the cover of BD expansion slot. After that, you'll see the status DIP switches for the K6 series PLC, as shown in the following image. With the CPU's front face as a reference, toggle the switch downwards for ON and upwards for OFF.



⚠️ Note: If the CPU detects a severe error while running, it will immediately enter the stopped state.

- I/O Indicator



[I0.0~I1.5]: DI status indicator lights, gray (off)/green (on), lights up with external input.

[Q0.0~Q1.1]: DO status indicators, gray (off)/green (on), lights up with control output.



[I0.0~I1.7]: DI status indicator lights, gray (off)/green (on), lights up with external input.

[Q0.0~Q2.7]: DO status indicators, gray (off)/green (on), lights up with control output.

2.2.3.2 BD Expansion

The BD expansion board is a circuit board that offers a small number of IO channels or communication expansion capabilities. It can be directly plugged into the CPU to enhance the functionality of the CPU module. The BD boards of the K6 series can be categorized into the following two types based on functionality:

1. Communication-type: provides serial communication (RS232/RS485) or CAN communication ports.
2. IO-type: provides a certain number of DI and DO channels. For product selection, please refer to the 1.4 product list.

For product selection, please refer to the [1.4 product list](#).

- KB6-CAN



The CAN interface supports CANopen master protocol, allowing a maximum of 64 connected

slaves. Each slave can have a maximum of 8 TPDOs and 8 RPDOs. It also supports error control mechanisms such as node guarding and heartbeat. For details on RJ45 pin definitions, please refer to [3.2.1 KB6-CAN](#).

The KB6-CAN comes with a built-in CAN terminal resistor. You can enable or disable the terminal resistor by the DIP switches, as shown in the diagram. Move the DIP switch to the side labeled "ON" to enable the terminal resistor, and move it to the opposite side to disable the terminal resistor.



When signals are transmitting, if the terminal impedance differs from the characteristic impedance, it can cause reflections and leading to signal distortion. The degree of distortion increases with the length of the transmission distance, resulting in communication errors. In such cases, it is recommended to enable terminal resistors to minimize signal distortion and ensure proper communication.

- KB6-2COM



KB6-2COM provides a RS232 interface (PORT0) and a RS485 interface (PORT3). Communication parameters can be configured in the [Comm] of the CPU under [Hardware].

- The RS232(PORT0) supports programming protocols, Modbus RTU slave, and free communication protocols.
- The RS485(PORT3) supports Modbus RTU master/slave and free communication protocols.

For DB9 definitions, please refer to section [3.2.2 KB6-2COM](#).

- KB6-4DI



The KB6-4DI module provides a set of 4 input channels, supporting NPN or PNP inputs. For wiring details, please refer to section [3.2.3 KB6-DI](#).

- KB6-4DO



The KB6-4DO module offers a set of 4 channels of solid-state relay-type DO (digital output). Each channel has a rated output current of 300mA and a maximum output current of 500mA. Additionally, it features channel short-circuit protection.

For wiring details, please refer to section [3.2.4 KB6-DO](#).

2.2.3.3 EtherNET

The K6 series CPU come with a 10/100M Ethernet (compliant with IEEE802.3 standards), in RJ45 format. Ethernet supports programming protocols and can be used as a programming interface. It also supports the Modbus TCP Client/Server industrial bus protocol, allowing free transmission and reception for TCP client/server and UDP peer communication. Furthermore, it supports program uploading and downloading as well as firmware upgrades, making it suitable for a wide range of application needs.



Indicator	Color	Status	Description
Green Light	Grey (Off)/Green (On)	On	100M communication
		Off	10M communication
		Blink	Currently sending and receiving data
		On	Currently no data is being sent or received

The default IP address for the K6 CPU module is 192.168.0.252. For communication configuration, please refer to section [6.6.1 Communication between PC and K6-series PLC](#).

2.2.3.4 Expansion Interface

The expansion interface is a dedicated expansion protocol interface for Kinco. It features integrated power supply and is used for module expansion. The K6 series CPU can support up to 14 expansion modules.

2.2.3.5 Data Maintain & Permanent Storage

DATA MAINTAIN refers to the ability to retain data stored in static random-access memory (SRAM) even after the CPU loses power, preserving the data in the same state it was before the power loss, then available for the CPU to use when it powers up again. The data retention function relies on a backup battery provided within the CPU to maintain power and preserve the data stored in SRAM memory after a power outage.

Operating with internal SRAM provides fast read/write speeds and unlimited memory lifespan. However, once the battery is depleted, all data will be lost. Under normal temperature conditions, data retention can last for a cumulative period of at least 3 years.

You need to select the range of data area (such as V area, C area, etc. Starting address, maximum length, etc.) in [Hardware] → [Reten].

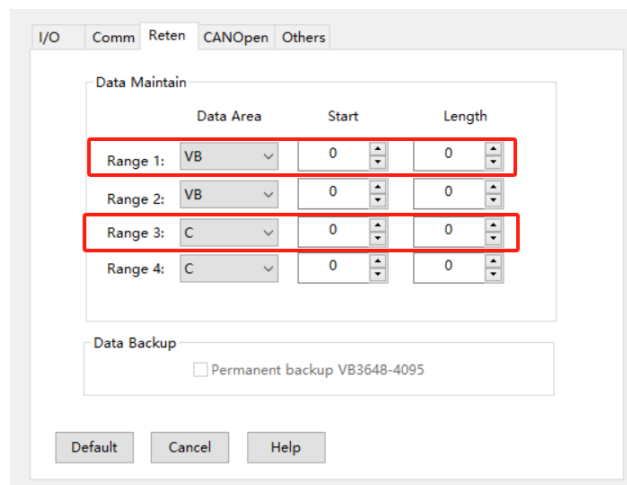

PERMANENT STORAGE refers to a designated area in the CPU's non-volatile memory (E²PROM). The data stored in this area will not be lost even when power is disconnected. However, the E²PROM has limitations in terms of lifespan and write speed, so frequent or rapid writes should be avoided.

The K series PLCs provide a permanent data storage area within the V area. The data in this area will be automatically written to the E²PROM, and you can directly utilize these areas during programming. For the K6 series PLC, the supported data backup areas are VB3648-VB4095 and VB15360-VB16383. You can choose to enable/disable the data backup function for specific address ranges in [Hardware] → [Others], as shown in the diagram provided.

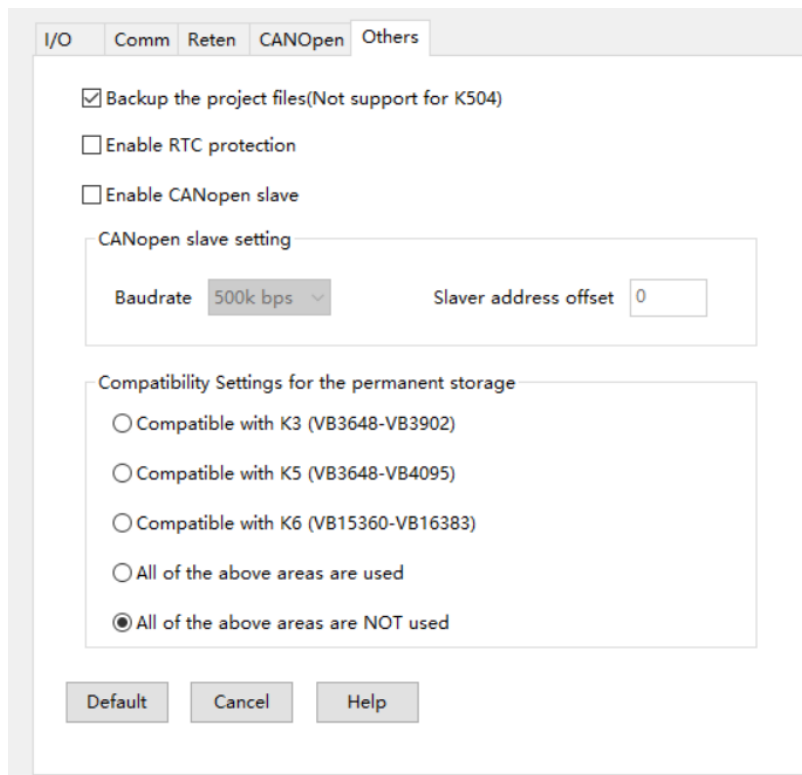

Option	Description
Compatible with K3 (VB3648-VB3902)	This option indicates that VB3648-3092 will be activated as the data backup area, and the data in this area will be automatically written into permanent storage(E ² PROM). (available for K-series PLC)
Compatible with K5 (VB3648-VB4095)	This option indicates that VB3648-4095 will be activated as the data backup area, and the data in this area will be automatically written into permanent storage(E ² PROM). (available for K-series PLC except K3, KS101M and K209M) 。
Compatible with K6 (VB15360-VB16383)	This option indicates that VB15360-16383 will be activated as the data backup area, and the data in this area will be automatically written into permanent storage(E ² PROM). (only available for K6, K6S, KS101M and K209M)
All of above areas are	This option indicates that VB3648-4095 and VB15360-16383 will be activated

used	together as the data backup area, and the data in this area will be automatically written into permanent storage(E ² PROM).(only available for K6 and K6S)
All of the above areas are NOT used	This option indicates that no permanent storage area will be configured.(only available for K6 and K6S)

⚠️ Note: The erase/write lifespan of the E²PROM is 1 million times(1,000,000). Therefore, data with high-frequency changes should not be stored in the addresses of the permanent storage area.

2.2.3.6 Real-time Clock

The K6 series CPU integrates a real-time clock (RTC), providing real-time time/calendar display. The format of the real-time clock/calendar (year/month/day, hour/minute/second) is encoded in BCD format, automatically adjusting for leap years. When the CPU is powered off, the real-time clock relies on backup battery power to maintain operation. At room temperature, the typical lifespan of the battery is 5 years, with a cumulative retention time of no less than 3 years in a power-off state.

When using the RTC for the first time, you need to set the clock by executing the [PLC] → [Adjust CPU Clock...] menu command in KincoBuilder. After that, the READ_RTC, SET_RTC, RTC_W, and RTC_R instructions can be used to implement related control functions.

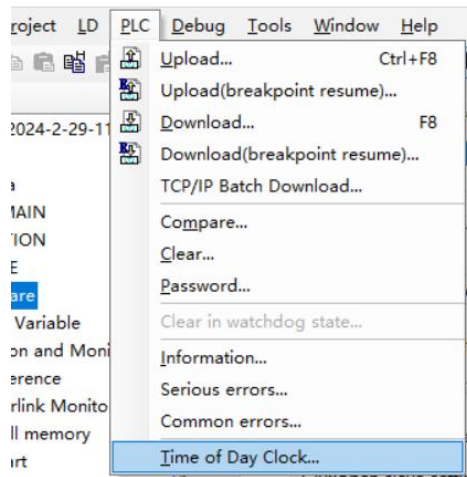

The K6 series CPU can monitor the battery voltage status through the special register(SM0.7). If SM0.7 is **TRUE**, it indicates low battery voltage; if SM0.7 is **FALSE**, it indicates normal battery voltage.

● **RTC Battery**

The K6 series CPU uses a specific specification lithium battery as the backup battery. When CPU is power off, the backup battery is used to power the real-time clock to maintain its operation and also powers the SRAM to retain data.

When the battery level is low, there will be an alarm message in KincoBuilder under [PLC Information] → [General Errors] prompting the user to replace the backup battery.

The backup battery can be removed, but it requires removing the cover for replacement. After opening the casing, the battery, as shown in the diagram on the right, you can see and replace. The battery is a lithium battery(CR2032, 3V). You can order the battery separately; for detailed ordering information, please contact the sales service center.



● **Method for replacing the battery**

1. Use a small screwdriver to pry loose the catches on both sides of the casing, then remove the top cover of the CPU.
2. After opening the cover, you will see the RTC battery on the upper circuit board. To ensure the battery's stability, it is typically fixed with electronic adhesive silicone gel after installation. At this point, you need to remove the adhesive used for fixation.
3. Use a tool to gently pry the bottom left corner of the battery and remove the used battery.
4. Install the new battery into the battery slot: Ensure that the right-side catch is secured first, then press down, as shown in the diagram below:



5. Finally, to ensure the battery is securely installed, apply silicone adhesive along the left edge.

⚠️ Note: Please follow local waste disposal and recycling regulations for proper disposal of the old lithium battery.

2.2.3.7 High-speed Inputs

The K6 series CPU supports 4 high-speed inputs. Among them, HSC0 and HSC1 support single-phase/dual-phase/AB phase(up to 200kHz), while HSC2 and HSC3 support single-phase(up to 20kHz) and dual-phase(up to 10kHz).

● Channel allocation and operating modes

HSC0					
Mode	Description	I0.1	I0.0	I0.5	
0	Single-phase up/down counter with internal direction control	Clock			
1			Reset		
2	Dir-control Register(bit): SM37.3		Reset	Start	
3	Single-phase up/down counter with external direction control	Clock		Dir	
4			Reset	Dir	
6	Dual-phase counter with up/down counting clock	Clock (decrease)	Clock (increase)		
9	A/B phase quadrature counter	Clock-A	Clock-B		
HSC1					
Mode	Description	I0.4	I0.6	I0.3	I0.2
0	Single-phase up/down counter with internal direction control			Clock	
1		Reset			
2	Dir-control Register(bit): SM47.3	Reset	Start		
3	Single-phase up/down counter with external direction control			Clock	Dir
4		Reset			Dir
6	Dual-phase counter with up/down counting clock			Clock (decrease)	Clock (increase)
7		Reset			
9	A/B phase quadrature counter			Clock-A	Clock-B
10		Reset			
HSC2					
Mode	Description	I0.4		I0.5	
0	Single-phase up/down counter with internal direction control Dir-control Register(bit): SM57.3			Clock	
9	A/B phase quadrature counter	Clock-B		Clock-A	
HSC3					
Mode	Description	I0.6		I0.7	

0	Single-phase up/down counter with internal direction control Dir-control Register(bit): SM127.3		Clock
9	A/B phase quadrature counter	Clock-B	Clock-A

2.2.3.8 High-speed Outputs

The K6 series CPUs, including models K606-24DT / K606-24AT / K606EA-30DT / K606EA-30AT / K608-40DT / K608-40AT, all support 4 channels of high-speed output. Channels-0 ~ Channel-2 have a maximum output frequency of 200kHz, while channel 3 has a maximum output frequency of 10kHz. All channels support PTO (Pulse Train Output, pulse + direction) and PWM (Pulse Width Modulation) output modes. Additionally, the software provides PLS (PWM or PTO), positioning control instruction set, PFLO_F (follow instruction), etc., making it convenient for users to implement simple motion control applications.

- **Usage of high-speed counters:**

1. Programming with relevant instructions: This method requires setting corresponding control registers in the program and calling the HDEF instruction and HSC instruction for programming. It is suitable for both single-segment PV setting mode and multi-segment PV setting mode. For more detailed guidance, please refer to the programming manual.

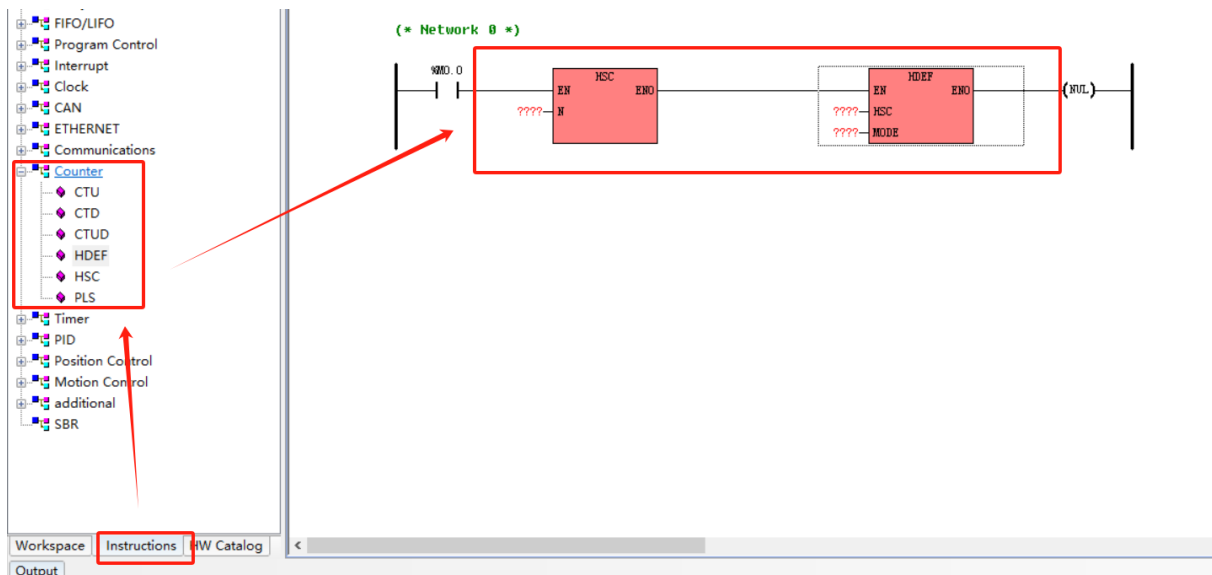

2. Configuration with HSC wizard: This method is simple and intuitive, requiring only to check the settings provided in the wizard. It is suitable for both single-segment PV setting mode and multi-segment PV setting mode. It is recommended to use the wizard for configuration, as it is easy, convenient, and saves programming time.

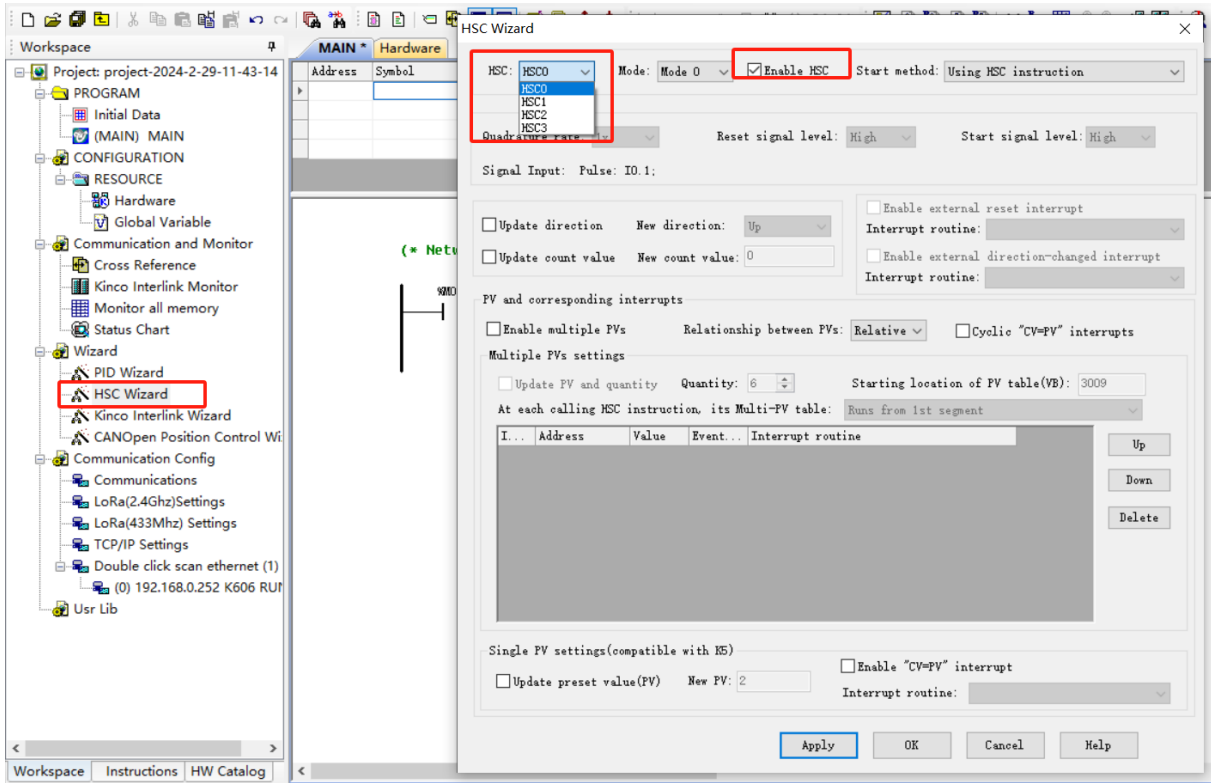

● Channel Allocation

Mode	Definition	Channel0	Channel1	Channel2	Channel3
PTO (Pulse Train)	Output	Q0.0	Q0.1	Q0.4	Q0.5
PTO (Pulse+Direction)	Pulse Output	Q0.0	Q0.1	Q0.4	Q0.5
	Direction Output	Q0.2	Q0.3	Q0.6	Q0.7
PWM	Output	Q0.0	Q0.1	Q0.4	Q0.5

2.2.3.9 External Interruption

The K6-series PLC support external interrupt function(IO.0 ~ IO.3). This allows for the utilization of the edge status of input signals to implement interrupts, thereby quickly capturing the rising or falling edges of inputs. This feature enables quick response to input signals with pulse widths smaller than the CPU scan cycle. For more detailed guidance and examples, please refer to the programming manual.

2.2.3.10 Integrated Power Supply

The CPU has an integrated power supply for supplying power to the CPU itself, the integrated DC24V output power supply (VO+, VO-), and the expansion bus.

The integrated power supply of the CPU provides two specifications of power for the expansion bus: +5V and +24V. All CPUs are designed with a DC24V output power supply capable of providing a maximum of 500mA of current.

When configuring expansion modules in the system, please carefully calculate the total capacity requirements to ensure that the +5V and +24V power supplies provided by the CPU can meet the needs of all expansion modules.

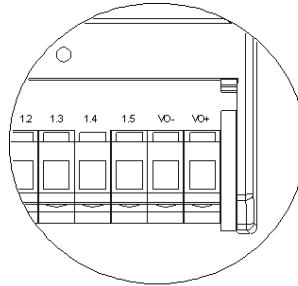

2.2.3.11 RS485

The K6 series CPU all provide 2 channels of RS485, named PORT1 and PORT2. All channels are designed with isolation in hardware to ensure stable and reliable communication operation. The supported protocols or functionalities for RS485 ports are as follows ("√" indicate support, "-" indicates not):

NO.	Modbus RTU	Programming&Debug	Free Communication
PORT1	√	√	√
PORT2	√	√	√

- Supports setting slave addresses from 1 to 127, with the default address being 1.
- Supports baud rates ranging from 1200bps to 115200bps.
- Supports master/slave mode.
- Each channel can connect up to 32 devices.

2.2.4 Specifications

2.2.4.1 Power Supply

	DC-powered	AC-powered
Power Supply (Voltage Range)	24V DC (±20%)	100-240V AC
Rated Power	40W	40W
Protection	Short Circuit Protection Reverse Polarity Protection	-

2.2.4.2 DI

Type and Polarity	NPN/PNP
Rated Input Voltage	DC24V, with a maximum allowable voltage of 30Vdc.
Rated Input Current	3.5mA@24VDC
Input Impedance	General channel: 6.8K Ω High-speed channel: 5.4K Ω
Logic "0" Max. Input Voltage	5V@0.7mA
Logic "0" Min. Input Voltage	15V@2.5mA
Input Delay	General channel<40 μ s High-speed channel<5 μ s
Isolation	Optocoupler isolation, 500VAC/minute
Status Indication	Corresponding LED lights up in green when an input signal is detected.

2.2.4.3 DO(Transistor)

Type and Polarity	PNP
Rated Output Voltage	DC24V, allowable range: DC20.4V~DC28.8V.
Output Current per Channel	500mA @ 24VDC Max.
Output Leakage Current	10 μ A Max.
Output Impedance	0.2 Ω Max.
Output Delay	General channel<25 μ s High-speed channel<2.5 μ s
Protection	Inductive load output protection Short circuit protection Output polarity reversal protection, allowing the application of reverse polarity signals at the output terminal for up to 10 seconds.
Channel parallel	Only support between channels within the same group.
Isolation	Optoelectronic isolation, 500VAC/minute
Status Indication	Corresponding LED lights up in green when an output signal is detected.

2.2.4.4 DO(Relay)

Type and Polarity	Relay
Allowed load voltage	DC 30V/AC250V
Allowed load current	2A (DC 30V/AC250V)
Output Current per Group	8A,Max. (4-channel/group)
Turn-on Delay	<10ms
Turn-off Delay	<5ms
Expected lifespan (contact)	Mechanical (no load): 20,000,000 times (1200 times/minute) Electrical (rated load): 100,000 times (6 times/minute)
Isolation	Relay isolation Isolation voltage between coil and contacts: 2000Vrms.
Status Indication	Corresponding LED lights up in green when an output signal is valid.

2.2.4.5 AI

Signal	4~20mA, 1~5V, 0~20mA, 0~10V
Resolution	12 bits
Accuracy	0.3% F.S.
Conversion Rate (per channel)	≈30 times/second
Input Impedance	Current-mode: ≤50 Ω Voltage-mode: >4M Ω
Anti-common-mode Voltage	(signal voltage + common mode voltage)≤12V, the channel will enter a protection state if the voltage exceeds the specified range.
Status Indicator	The corresponding channel LED will turn red to indicate that the input value has exceeded the selected range.

2.2.4.6 AO

Signal	4~20mA, 1~5V, 0~20mA, 0~10V
Resolution (including sign bit)	12 bits
Accuracy	0.3% F.S.(Full Scale)
Conversion Rate (per channel)	≈300 times/second

External Load	Current-mode: Maximum 500 Ω Voltage-mode: Minimum 1k Ω
---------------	---

2.2.4.7 Communication Interface

RS485	2*RS485, with physical isolation design. Baud rate range: 1200bps~115200bps. PORT1 supports programming protocols, Modbus RTU master/slave, and free communication. PORT2 supports programming protocols, Modbus RTU master/slave, and free communication.
Ethernet	1* Ethernet, supports Modbus TCP Client/Server, Modbus UDP industrial bus protocol, TCP client/TCP server free transmission, UDP peer free transmission, program upload/download, and firmware upgrade.
BD Expansion	1~2
Local Expansion Bus ¹	Supports connection of up to 14 K6-series expansion modules (compatible with K5-series modules).

2.2.4.8 Storage & RTC

Program Capacity	8k instructions
Data Capacity	M-area: 4k bytes, V-area: 16k bytes
Timer	256 Timers: 1ms time base: 4 10ms time base: 16 100ms time base: 236
Counter	256
Data Backup	E ² PROM, 1k bytes
Power-off Retention	V-area: 16k bytes C-area(Counter): 512 bytes
RTC	Operating environment: At 25°C, the error is less than 5 minutes per month.
Battery	Supports battery voltage monitoring and battery replacement.

¹ Local Expansion Bus: Used for connecting the CPU and expansion modules, the expansion interface employs a pin-socket physical medium. Integrated within the expansion bus are the data bus, address bus, and power supply for the expansion modules.

2.2.4.9 BD Expansion Modules

Model	KB6-4DO
channels(Output)	4 channels
Type and Polarity	NPN/PNP
Connector	3.81mm, Terminal block
Rated Output Voltage	DC24V, allowable range: DC20.4V~28.8VDC。
Rated Output Current	300mA@24VDC Max.
Output Leakage Current	1 μ A, Max.
Output Impedance	2.5 Ω , Max.
Output Delay	<10ms
Protection	Inductive Load Output Protection Short Circuit Protection
Channel parallel	Only support between channels within the same group.
Isolation	Optocoupler isolation, 500VAC/minute
Status Indication	The LINK light being on indicates that the module is properly connected.

Model	KB6-4DI
Channels(Input)	4 channels
Type and Polarity	NPN/PNP
Connector	3.81mm Terminal block.
Rated Input Voltage	DC24V, allowable range: DC20.4V~28.8VDC。
Rated Input Current	3.5mA@24VDC
Logic "0" Max. Input Voltage	5V@0.7mA
Logic "0" Min. Input Voltage	11V@2.0mA
Input Delay	<40 μ s
Isolation	Optocoupler isolation, 500VAC/minute
Status Indication	The LINK light being on indicates that the module is properly connected.

Model	KB6-2COM
Functionality	1*RS232(PORT0), 1*RS485(PORT3)

Connector	DB9
Transmission Rate	1200bps~115200bps
Protocols	RS232: Modbus RTU Slave, Free Communication, Programming Protocol
	RS485: Modbus RTU Master/Slave, Programming Protocol
Status Indication	The LINK light being on indicates that the module is properly connected.

Model	KB6-CAN
Functionality	1*CAN (CAN2)
Connector	RJ45
Transmission Rate	10kbps, 20kbps, 50kbps, 125kbps, 500kbps, 800kbps, 1000kbps
Protocols	Canopen, Kinco-motion-control protocols, CAN Free Communication
Status Indication	The LINK light being on indicates that the module is properly connected.

2.3 Expansion Modules

2.3.1 Components

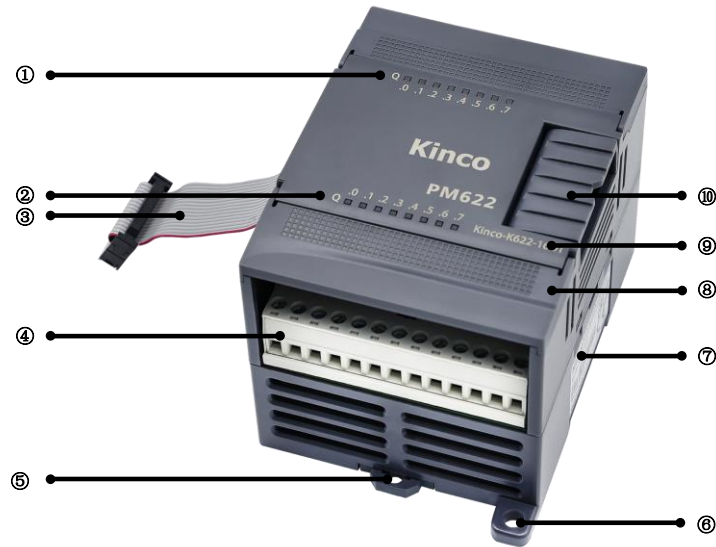

No.	Item	Description
①	Status Indicator	Digital module: Displays the connection status of each channel, lit (green) when connected, extinguished when not connected; Analog module: Displays the operating status of each channel, lit (red) indicates exceeding limits, extinguished indicates normal status.
②	Status Indicator	Digital module: Displays the connection status of each channel, lit (green) when connected, extinguished when not connected; Analog module: Displays the operating status of each channel, lit (red) indicates exceeding limits, extinguished indicates normal status.
③	Expansion Cable	For extended connectivity.
④	Screw-fastening Terminals	For wiring of inputs and outputs with screws and terminals are removable .
⑤	Rail Card Slot Slider (35mm)	For mounting on DIN rail.
⑥	Bolt Mounting Hole(M4)	Can be reinforced with M4 bolts.

⑦	Product Label	Display product model number, serial number and other information.
⑧	Terminal Cover	Prevents substances from dripping or splashing on the terminal screws, flip up the cover to see the channel labeling.
⑨	Product Model	For checking the current PLC model.
⑩	Expansion Interface	Used for connecting expansion modules.

2.3.2 Specifications

2.3.2.1 K621-08DX

K621-08DX is a digital input module with 8 channels, including 2 sets (4 channels/set) of digital inputs.

Technical Specifications	
Input-channel	8 (4 channels/set, 2 sets)
Type and Polarity	NPN/PNP
Rated Input Voltage	DC 24V
Rated Input Current	3.5mA@24VDC
Input Impedance	6.8K Ω
Logic "0" Max. Input Voltage	5V
Logic "1" Min. Input Voltage	11V@2.0mA
Input Delay	<40 μ s
Current Loss(E-bus)	\leq 180mA (5V)
Isolation	Optoelectronic isolation, 500VAC/minute
State Instruction	Corresponding LED lights up in green when an output signal is valid.
Digital Image Area	
DI Image Area	1 byte
DO Image Area	-
Dimensions and Weight	
Dimensions (Length \times Width \times Height)	114 \times 50 \times 70mm
Net Weight	125g

2.3.2.2 K621-16DX

The modules are connected by the expansion bus, communicating via a special bus protocol from Kinco, and the module power supplies are already integrated in the expansion bus.

Technical Specifications	
Input-channel	16 (8 channels/set, a total of 2 sets)
Type and Polarity	NPN/PNP
Rated Input Voltage	DC 24V
Rated Input Current	3.5mA@24VDC
Input Impedance	6.8k Ω
Logic "0" Max. Input Voltage	5V
Logic "1" Min. Input Voltage	11V@2.0mA
Input Delay	<40 μ s
Current Loss(E-bus)	\leq 210mA (5V)
Isolation	Optoelectronic isolation, 500VAC/minute
Status Indication	Corresponding LED lights up in green when an input signal is detected.
Digital Image Area	
DI Image Area	2 bytes
DO Image Area	-
Dimensions and Weight	
Dimensions (Length \times Width \times Height)	114 \times 75 \times 70mm
Net Weight	150g

2.3.2.3 K622-08DT

K622-08DT is a transistor-type digital output module with 8 channels, including 2 sets(4 channels/set) of transistor outputs(PNP).

Technical Specifications	
Output-channel	8 (4 channels/set, a total of 2 sets)
Type and Polarity	PNP
Rated Output Voltage	DC24V, allowable range: DC20.4V~DC28.8V.
Output Current per	500mA@24VDC, Max.
Output Leakage	10 μ A, Max.
Output Impedance	0.2 Ω , Max
Output Delay	<25 μ s
Protection	Inductive load output protection Short circuit protection Output polarity reversal protection, allowing the application of reverse polarity signals at the output terminal for up to 10 seconds.
Channel parallel	Only support between channels within the same group.
Current Loss(E-bus)	\leq 200mA (5V)
Isolation	Optoelectronic isolation, 500VAC/minute 500VAC/minute
Status Indication	Corresponding LED lights up in green when an output signal is valid.
Digital Image Area	
DI Image Area	-
DO Image Area	1 byte
Dimensions and Weight	
Dimensions (Length \times Width \times Height)	114 \times 50 \times 70mm
Net Weight	125g

2.3.2.4 K622-08XR

The K622-08XR is a output module with 8 channels, including 2 sets(4 channels/set) of relay outputs.

Technical Specifications	
Output-channel	8 (4 channels/set, a total of 2 sets)
Allowed load voltage	DC30V / AC250V
Allowed load current	2A (DC30V / AC250V)
Output Current per Group	8A, Max.
Turn-on Delay	≤10ms
Turn-off Delay	≤5ms
Current Loss(E-bus)	≤ 180mA (5V)
	≤ 60mA (24V)
Expected lifespan (contact)	Mechanical (no load): 20,000,000 times (1200 times/minute)
	Electrical (rated load): 100,000 times (6 times/minute)
Isolation	Relay isolation
	Isolation voltage between coil and contacts: 2000Vrms.
Status Indication	Corresponding LED lights up in green when an output signal is valid.
Digital Image Area	
DI Image Area	-
DO Image Area	1 byte
Dimensions and Weight	
Dimensions (Length × Width × Height)	114×50×70mm
Net Weight	150g

2.3.2.5 K622-16DT

The K622-16DT is a transistor-type digital output module with 16 channels, including 4 sets(4 channels/set) of outputs(PNP).

Technical Specifications	
Output-channel	16 (4 channels/set, a total of 4 sets)
Type and Polarity	PNP
Rated Output Voltage	DC24V, allowable range: DC20.4V~DC28.8V.
Output Current per	500mA@24VDC
Output Leakage	10 μ A, Max.
Output Impedance	0.2 Ω , Max.
Output Delay	<25 μ s
Protection	Inductive load output protection Short circuit protection Output polarity reversal protection, allowing the application of reverse polarity signals at the output terminal for up to 10 seconds.
Channel parallel	Only support between channels within the same group.
Current Loss(E-bus)	\leq 240mA (5V)
Isolation	Optoelectronic isolation, 500VAC/minute
Status Indication	Corresponding LED lights up in green when an output signal is valid.
Digital Image Area	
DI Image Area	-
DO Image Area	2 bytes
Dimensions and Weight	
Dimensions (Length \times Width \times Height)	114 \times 75 \times 70mm
Net Weight	170g

2.3.2.6 K622-16XR

K622-16XR is a relay output module with 16 channels, including 4 sets(4 channels/set) of relay outputs.

Technical Specifications	
Output-channel	16 (4 channels/set, a total of 4 sets)
Allowed load voltage	DC 30V/AC250V
Allowed load current	2A (DC 30V/AC250V)
Output Current per Group	8A, Max.
Turn-on Delay	≤10ms
Turn-off Delay	≤5ms
Current Loss(E-bus)	≤ 210mA (5V)
	≤ 120mA (24V)
Expected lifespan (contact)	Mechanical (no load): 20,000,000 times (1200 times/minute)
	Electrical (rated load): 100,000 times (6 times/minute)
Isolation	Relay isolation
	Isolation voltage between coil and contacts: 2000Vrms.
Status Indication	Corresponding LED lights up in green when an output signal is valid.
Digital Image Area	
DI Image Area	-
DO Image Area	2 bytes
Dimensions and Weight	
Dimensions (Length × Width × Height)	114×75×70mm
	Net Weight

2.3.2.7 K623-08DT

K623-08DT is a hybrid module with 8 channels, including 1 set of inputs (4 channels/set) and 1 set of PNP outputs (4 channels/set, transistor).

Technical Specifications	
Input-channel	4 (4 channels/set, a total of 1 set)
Type and Polarity	NPN/PNP
Rated Input Voltage	DC 24V
Rated Input Current	3.5mA@24VDC
Input Impedance	6.8K Ω
Logic "0" Max. Input Voltage	5V
Logic "1" Min. Input Voltage	11V@2.0mA
Output-channel	4 (4 channels/set, a total of 1 set)
Type and Polarity	PNP
Rated Output Voltage	DC24V, allowable range: DC20.4V~DC28.8V.
Output Current per	500mA@24VDC
Output Leakage	10 μ A, Max.
Output Impedance	0.2 Ω , Max.
Output Delay	<25 μ s
Protection	Inductive load output protection Short circuit protection Output polarity reversal protection, allowing the application of reverse polarity signals at the output terminal for up to 10 seconds.
Channel parallel	Only support between channels within the same group.
Current Loss(E-bus)	\leq 200mA (5V)
Isolation	Optoelectronic isolation, 500VAC/minute 500VAC/minute
Status Indication	Corresponding LED lights up in green when an output/input signal is valid.
Digital Image Area	
DI Image Area	1 byte
DO Image Area	1 byte
Dimensions and Weight	
Dimensions	114×50×70mm

(Length × Width × Height)	
Net Weight	125g

2.3.2.8 K623-08DR

K623-08DR is a hybrid module with 8 channels, including 1 set of inputs (4 channels/set) and 1 set of relay outputs (4 channels/set).

Technical Specifications	
Input-channel	4 (4 channels/set, a total of 1 set)
Type and Polarity	NPN/PNP
Rated Input Voltage	DC 24V
Rated Input Current	3.5mA@24VDC
Logic "0" Max. Input Voltage	5V
Logic "1" Min. Input Voltage	11V@2.0mA
Isolation	Optoelectronic isolation, 500VAC/minute 500VAC/minute
Output-channel	4 (4 channels/set, a total of 1 set)
Allowed load voltage	DC 30V/AC250V
Allowed load current	2A (DC 30V/AC250V)
Output Current per Group	8A, Max.
Turn-on Delay	≤10ms
Turn-off Delay	≤5ms
Expected lifespan (contact)	Mechanical (no load): 20,000,000 times (1200 times/minute) Electrical (rated load): 100,000 times (6 times/minute)
Isolation	Relay isolation Isolation voltage between coil and contacts: 2000Vrms.
Current Loss(E-bus)	≤ 180mA (5V) ≤ 30mA (24V)
Status Indication	Corresponding LED lights up in green when an output/input signal is valid.
Digital Image Area	
DI Image Area	1 byte
DO Image Area	1 byte

Dimensions and Weight	
Dimensions (Length × Width × Height)	114×50×70mm
Net Weight	145g

2.3.2.9 K623-16DT

K623-16DT is a hybrid module with 16 channels of digital input and digital output. It includes 2 sets (4 channels/set) of inputs and 2 sets (4 channels/set) of PNP-type outputs(transistor).

Technical Specifications	
Input-channel	8 (8 channels/set, a total of 1 set)
Type and Polarity	NPN/PNP
Rated Input Voltage	DC 24V
Rated Input Current	3.5mA@24VDC
Logic "0" Max. Input Voltage	5V
Logic "1" Min. Input Voltage	11V@2.0mA
Output-channel	8 (4 channels/set, a total of 2 sets)
Type and Polarity	PNP
Rated Output Voltage	DC24V, allowable range: DC20.4V—DC28.8V
Output Current per	500mA@24VDC, Max.
Output Leakage	10 μ A, Max.
Output Impedance	0.2 Ω , Max.
Output Delay	<25 μ s
Channel parallel	Only support between channels within the same group.
Current Loss(E-bus)	≤ 230ms (5V)
Isolation	Optoelectronic isolation, 500VAC/minute 500VAC/minute
Status Indication	Corresponding LED lights up in green when an output/input signal is valid.
Digital Image Area	
DI Image Area	1 byte
DO Image Area	1 byte
Dimensions and Weight	
Dimensions (Length × Width × Height)	114×75×70mm

Net Weight	165g
------------	------

2.3.2.10 K623-16DR

The K623-16DR is a hybrid module with 16 channels, including 1 set of digital input (8 channels/set) and 2 sets of relay output (4 channels/set).

Technical Specifications	
Input-channel	8 (8 channels/set,a total of 1 set)
Type and Polarity	NPN/PNP
Rated Input Voltage	DC 24V
Rated Input Current	3.5mA@24VDC
Logic "0" Max. Input Voltage	5V
Logic "1" Min. Input Voltage	11V@2.0mA
Isolation	Optoelectronic isolation, 500VAC/minute 500VAC/minute
Output-channel	8 (Relay, 4 channels/set, a total of 2 sets)
Allowed load voltage	DC 30V/AC250V
Allowed load current	2A (DC 30V/AC250V)
Output Current per Group	8A, Max.
Turn-on Delay	≤10ms
Turn-off Delay	≤5ms
Expected lifespan (contact)	Mechanical (no load): 20,000,000 times (1200 times/minute) Electrical (rated load): 100,000 times (6 times/minute)
Isolation	Relay isolation Isolation voltage between coil and contacts: 2000Vrms.
Current Loss(E-bus)	≤ 210mA (5V)
	≤ 60mA (24V)
Status Indication	Corresponding LED lights up in green when an output/in put signal is valid.
Digital Image Area	
DI Image Area	1 byte
DO Image Area	1 byte
Dimensions and Weight	
Dimensions	114×75×70mm

(Length × Width × Height)	
Net Weight	165g

2.3.2.11 K631-04IV

The K631-04IV has 4 analog input channels and supports the measurement of voltage or current signals within the range of 4~20mA, 1~5V, 0~20mA, and 0~10V.

Technical Specifications	
Channels	4
Rated Power Supply	DC 24V, ≥100mA
Signal	4-20mA, 1-5V, 0-20mA, 0-10V
Resolution	12 bits
Output Accuracy	0.3% F.S.
Input Limits	Current input not exceeding 24mA, voltage input not exceeding 12V.
Conversion Rate (per channel)	Approximately 15 times/second
Input Impedance	Current-mode: ≤500 Ω Voltage-mode: >4M Ω
Current Loss(E-bus)	≤ 172mA (5V)
Status Indication	The corresponding channel LED will turn red to indicate that the input value has exceeded the selected range.
Digital Image Area	
AI Image Area	8 bytes (2 bytes/channel)
AO Image Area	-
Dimensions and Weight	
Dimensions (Length × Width × Height)	114×50×70mm
Net Weight	136g

- **Measurement Range and Value**

The input signal is sampled by the ADC, linearly calculated, and the calculation result is stored as the measured value in the AI image area for access by the user program. Different type of signal have specific measurement ranges. If the measured value exceeds the rated measurement range, the module will alarm: the LED light will illuminate (red), and the module will automatically send a fault message to the CPU module.

If there are AI channels that are not needed, it is recommended that short-circuit the channels and set the corresponding signal in the KincoBuilder as [0-20mA] or [0-10V], to artificially put these channels in a working state and dissipate accumulated charges through short-circuiting to prevent interference-induced module alarms. When short-circuiting, please short-circuit three terminals of the same group together:

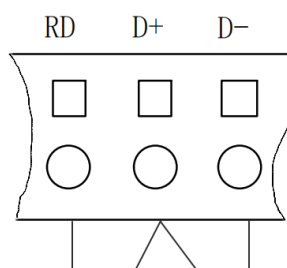

The table below shows the representation format for measurement range and measurement value, where “I” represents the actual current input value, and “V” represents the actual voltage input value.

Signal	Measurement Range	Measure Value
4~20mA	3.92~20.4mA	I×1000 (3920-20400)
0~20mA	0~20.4mA	I×1000 (0-20400)
1~5V	0.96~5.1V	V×1000 (960-5100)
0~10V	0~10.2V	V×1000 (0-10200)

2.3.2.12 K631-04TC

The K631-04TC module provides 4 measurement channels, all supporting J-type, K-type, E-type, and S-type thermocouple measurements. The compensation modes include both cold junction internal compensation and external compensation.

Technical Specifications	
Channel	4
Rated Power Supply	DC 24V, ≥100mA
Signal	J, K, E, S
Compensation Method	Cold junction internal compensation or cold junction external compensation optional.
Resolution (including sign bit)	24 bits
Accuracy	0.1% F.S.
Conversion Rate (per channel)	Approximately 1 time/second
Input Impedance	>20KΩ

Current Loss(E-bus)	≤ 172mA (5V)
Status Indication	The corresponding channel LED will turn red to indicate that the input value has exceeded the selected range.
Digital Image Area	
AI Image Area	8 bytes (2 bytes/channel)
AO Image Area	-
Dimensions and Weight	
Dimensions (Length × Width × Height)	114×50×70mm
Net Weight	132g

● **Measurement Range and Value**

The input signal undergoes A/D conversion and the resulting value is calculated according to the standard thermocouple graduation table. The converted result is then stored in the CPU's analog input (AI) area for user program access.

Different signal forms have their measurement ranges. If the measured value exceeds the rated measurement range, the module will trigger an alarm: the LED light of the channel exceeding the range will be illuminated (red), and the module will automatically send a fault message to the CPU module. Below is the measurement range and representation format, where T represents the measured temperature value.

Signal	Measurement Range	Measurement Value
J-type	-210~1200°C	T×10 (-2100~12000)
K-type	-270~1300°C	T×10 (-2700~13000)
E-type	-270~1000°C	T×10 (-2700~10000)
S-type	-50~1600°C	T×10 (-500~16000)

2.3.2.13 K631-04RD

The K631-04RD module has 4 sets of resistance temperature detector (RTD) measurement channels, supporting Pt100, Pt1000, Cu50 type(two-wire or three-wire) temperature measurements, and also supports direct measurement of resistance values.

Technical Specifications	
Channels	4
Rated Power Supply	DC 24V, $\geq 100\text{mA}$
Signal	Pt100, Cu50, Pt1000, Resistor
Wiring-type	Two-wire or Three-wire
Resolution (including sign bit)	24 bits
Accuracy	Temperature: $\pm 0.5^{\circ}\text{C}$; Resistor: $\pm 1\Omega$
Conversion Rate (per channel)	Approximately 1 time/second
Input Impedance	$> 1\text{M}\Omega$
Current Loss(E-bus)	$\leq 172\text{mA}$ (5V)
Status Indication	The corresponding channel LED will turn red to indicate that the input value has exceeded the selected range.
Digital Image Area	
AI Image Area	8 bytes (2 bytes/channel)
AO Image Area	-
Dimensions and Weight	
Dimensions (Length \times Width \times Height)	114 \times 50 \times 70mm
Net Weight	132g

- **Measurement Range and Value**

The input signal is sampled by the ADC, linearly calculated, and the calculation result is stored as the measured value in the AI image area for access by the user program. Different type of signal have specific measurement ranges. If the measured value exceeds the rated measurement range, the module will alarm: the LED light will illuminate (red), and the module will automatically send a fault message to the CPU module.

The table below shows the representation format for measurement range and measurement value, where “I” represents the actual current input value, and “V” represents the actual voltage input value.

Signal	Measurement Range	Measurement Value
--------	-------------------	-------------------

Pt100	-200~850℃	$T \times 10(-2000 \sim 8500)$
Cu50	-50~150℃	$T \times 10(-500 \sim 1500)$
Pt1000	-50~300℃	$T \times 10(-500 \sim 3000)$
Resistor	0~2000Ω	$R \times 10(0 \sim 20000)$

2.3.2.14 K632-02IV

The K632-02IV module provides two analog output channels, supporting current and voltage outputs, all of them support voltage or current signals (4~20mA, 1~5V, 0~20mA, 0~10V).

Technical Specifications	
channels	2
Rated Power Supply	DC 24V $\geq 100\text{mA}$
Signal	4-20mA, 1-5V, 0-20mA, 0-10V
Resolution (including sign bit)	12 bits
Output Accuracy	0.3% F.S.
Conversion Rate (per channel)	Approximately 15 times/second
External Load	Current-mode: $\leq 500 \Omega$ Voltage-mode: $\geq 1\text{K} \Omega$
Current Loss(E-bus)	$\leq 160\text{mA}$ (5V)
Status Indication	The corresponding channel LED will turn red to indicate that the input value has exceeded the selected range.
Digital Image Area	
AI Image Area	-
AO Image Area	4 bytes (2 bytes/channel)
Dimensions and Weight	
Dimensions (Length \times Width \times Height)	114 \times 50 \times 70mm
Net Weight	125g

- **Measurement Range and Value**

The AQ output values specified in the user project are transmitted to the respective analog output modules through the expansion bus firstly. Then, after calculation, transformation, and DAC conversion, they are output to the specified AO channels. Different types of signal have their rated output ranges. If the specified output value in the user program exceeds the upper or lower limits of the rated range, the corresponding values of the upper or lower limits will still be output.

The table below shows the representation format for measurement range and measurement value, where “I” represents the actual current output value, and “V” represents the actual voltage output value.

Signal	Output Range	Output Value
4~20mA	3.92~20.4mA	$I \times 1000$ (3920~20400)
0~20mA	0~20.4mA	$I \times 1000$ (3920~20400)
1~5V	0.96~5.1V	$V \times 1000$ (960~5100)
0~10V	0~10.2V	$V \times 1000$ (0~10200)

2.3.2.15 K633-04IV

K633-04IV module is a hybrid module with 2 analog inputs and 2 analog outputs, all of them support voltage or current signals (4~20mA, 1~5V, 0~20mA, 0~10V).

Technical Specifications	
AI Channels	2
Power Supply	DC 24V, $\geq 100\text{mA}$
Type	4-20mA, 1-5V, 0-20mA, 0-10V
Resolution	12 bits
Measurement Accuracy	0.3% F.S.
Input Limits	Current input $\leq 24\text{mA}$ Voltage input $\leq 12\text{V}$
Conversion Rate (per channel)	Approximately 15 times/second
Input Impedance	I-mode: $\leq 500\ \Omega$ V-mode: $> 4\text{M}\ \Omega$
AO Channels	2
Power Supply	DC 24V $\geq 100\text{mA}$
Type	4-20mA, 1-5V, 0-20mA, 0-10V
Resolution (including sign bit)	12 bits
Output Accuracy	0.3% F.S.
Conversion Rate (per channel)	Approximately 15 times/second
External Load Capacity	I-mode: $\leq 500\ \Omega$ V-mode: $> 1\text{k}\ \Omega$
Others	
Current Loss(E-bus)	$\leq 166\text{mA}$ (5V)
State Instruction	When the value of the channel exceeds the rated range, the corresponding indicator light will illuminate (red)
Analog Image Area	
AI Image Area	4 bytes (2 bytes/channel)
AO Image Area	4 bytes (2 bytes/channel)
Dimensions and Weight	
Dimensions (Length \times Width \times Height)	114 \times 50 \times 70mm
Net Weight	136g

● **Measurement Range and Value**

The input signal is sampled by the ADC, linearly calculated, and the calculation result is stored as the measured value in the AI image area for access by the user program. Different type of signal have specific measurement ranges. If the measured value exceeds the rated measurement range, the module will alarm: the LED light will illuminate (red), and the module will automatically send a fault message to the CPU module.

If there are AI channels that are not needed, it is recommended that short-circuit the channels and set the corresponding signal in the KincoBuilder as [0-20mA] or [0-10V], to artificially put these channels in a working state and dissipate accumulated charges through short-circuiting to prevent interference-induced module alarms. When short-circuiting, please short-circuit three terminals of the same group together:

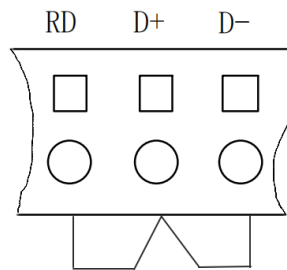

The table below shows the representation format for measurement range and measurement value, where “I” represents the actual current input value, and “V” represents the actual voltage input value.

Signal	Output Range (Actual value)	Input Value (in user project)
4~20mA	3.92~20.4mA	I×1000 (3920~20400)
0~20mA	0~20.4mA	I×1000 (0~20400)
1~5V	0.96~5.1V	V×1000 (960~5100)
0~10V	0~10.2V	V×1000 (0~10200)

The AQ output values specified in the user project are transmitted to the respective analog output modules through the expansion bus firstly. Then, after calculation, transformation, and DAC conversion, they are output to the specified AO channels. Different types of signal have their rated output ranges. If the specified output value in the user program exceeds the upper or lower limits of the rated range, the corresponding values of the upper or lower limits will still be output.

The table below shows the representation format for measurement range and measurement value, where “I” represents the actual current output value, and “V” represents the actual voltage output value.

Signal	Output Range (Actual value)	Output Value (in user project)
4~20mA	3.92~20.4mA	I×1000 (3920~20400)
0~20mA	0~20.4mA	I×1000 (0~20400)
1~5V	0.96~5.1V	V×1000 (960~5100)
0~10V	0~10.2V	V×1000 (0~10200)

2.3.2.16 K680

The expansion power supply module of the K6 series is also known as PS680, with the standard model being Kinco-K680.

This module is used to provide +5V(working power) and +24V (relay drive power) to the expansion module. The expansion modules need to be powered by the CPU through the expansion bus. Therefore, when selecting the specific PLC model, please pay attention to whether the power capacity provided by the CPU can meet the total power requirements of the required expansion modules. If not, the system will not work properly (resulting in the CPU module's power output overload protection). In this case, you can choose a CPU with a higher power supply capacity or configure PS680s in an appropriate position in the system to ensure that the system operates normally. Additionally, it is recommended to add a PS680 module when the number of connected expansion modules exceeds 7 to ensure the stable operation of the entire PLC system.

The expansion modules located after the CPU and before the PS680 are powered by the CPU, while those located after the PS680 are powered by the PS680. Therefore, in a system, please arrange the placement of the PS680 based on the power supply capacity of the CPU and PS680, as well as the total bus current loss of each expansion module.

The PS680 does not occupy the memory of the CPU and does not require to be configured in KincoBuilder; it is plug and play. In a same system, please ensure that the power supply of PS680 is consistent with the power supply of the CPU.

Specifications	
Power Supply	AC 85~265V
Capacity	≤1000mA (5V)
	≤250mA (24V)
State Instruction	Power (PW)
Dimensions and Weight	
Dimensions (Length × Width × Height)	114×75×70mm
Net Weight	195g

3 Wiring Instructions

3.1 CPU Unit

3.1.1 RS485

The K6 series CPU integrate two serial ports, named PORT1 and PORT2. All RS485 physical interfaces are fully isolated in hardware. The RS485 supports a maximum baud rate of 115200bps, supports Modbus RTU master/slave protocols, and free communication. Each RS485 interface supports a maximum of 32 devices in the network.

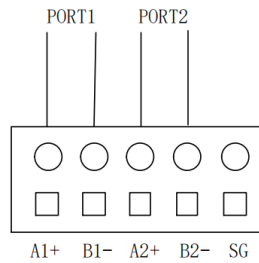

Symbol	Description
SG	Ground
B2	TXD-/B(Group2)
A2	TXD+/A(Group2)
B1	TXD-/B(Group1)
A1	TXD+/A(Group1)

The bus topology structure for RS485 is as follows. It is recommended that customers connect a 120Ω terminating resistor at each end of the bus when in use.

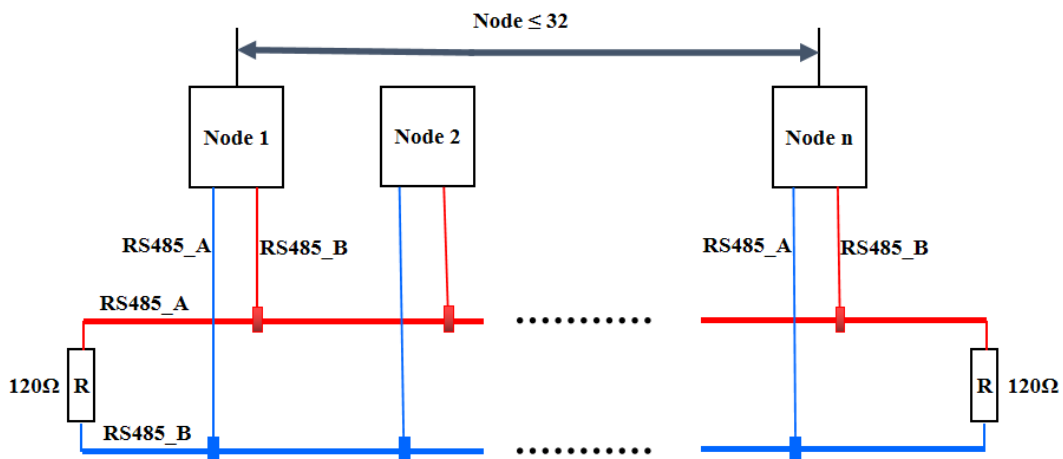

3.1.2 EtherNET

The EtherNET are available with straight-through or crossover cable, and it offer an "auto-negotiation" function: When a cable is plugged in, an automatic negotiation with the communicating party takes place to determine the type of cable to be used.

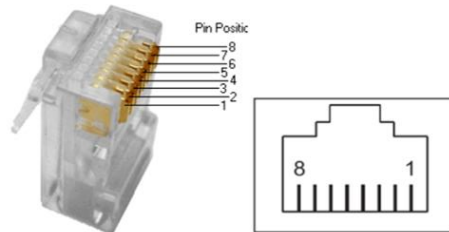

Pin	Signal	Description
1	TD+	Send+
2	TD-	Send-
3	RD+	Receive+
4		
5		
6	RD-	Receive-
7		
8		

3.1.3 Power Supply

- DC

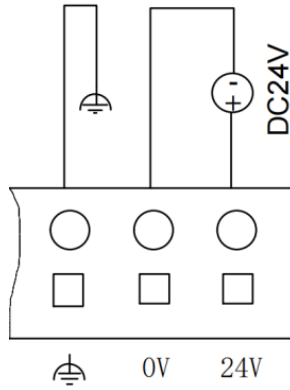

Symbol	Meaning
24V	Power Supply(24V DC+)
0V	Power Supply(24V DC-)
⏏	Ground (connect to earth)

When the CPU is properly powered up, the [Run] status indicator is always on (green).

- AC

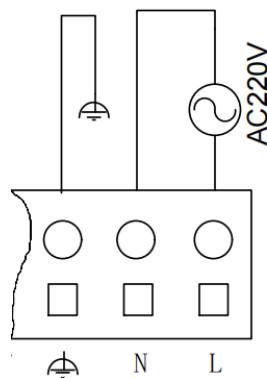

Symbol	Description
L	Positive terminal of the 220V AC power supply
N	Negative terminal of the 220V AC power supply
⏏	Ground (connected to earth)

When the CPU is properly powered up, the [Run] status indicator is always on (green).

3.1.4 I/O

3.1.4.1 DI

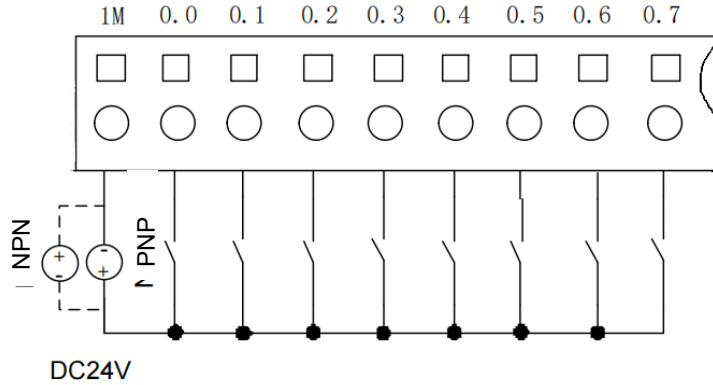

The CPU digital input supports both NPN and PNP. As shown in the diagram above, when the signal flows into the input terminal, it is referred to as NPN input; when the signal flows out from the DI common (1M), it is referred to as PNP input. In the diagram, solid lines represent external wiring for PNP input, while dashed lines represent external wiring for NPN input.

This diagram applies to all inputs in CPU K606, K608, and K606EA.

3.1.4.2 DO(Transistor)

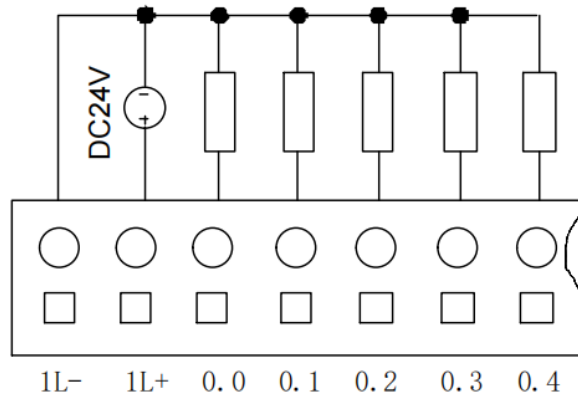

The CPU transistor-type outputs only support PNP type. PNP means that when a signal is triggered, the signal outputs as high-level. In the diagram above, 1L- is connected to the DC 24V-, 1L+ is connected to the DC 24V+, and the signal is connected to the external load.

This diagram applies to all CPUs' transistor-type outputs in CPU K606, K608, and K606EA.

3.1.4.3 DO(Relay)

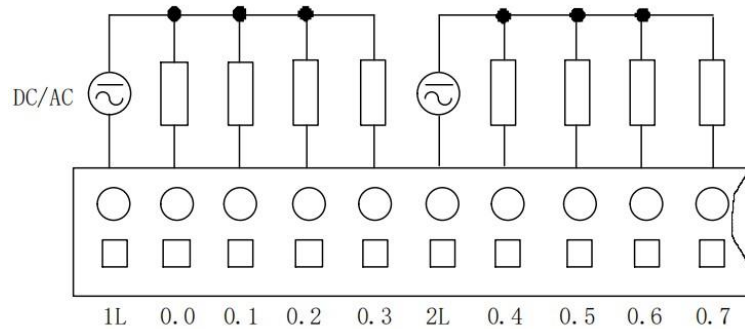

In the diagram above, 1L, 2L, and 3L are DO commons. Each common can be connected to a DC or AC power supply as needed.

⚠️ Note: The relay output-type CPU modules do not support high-speed output function.

3.1.4.4 AI

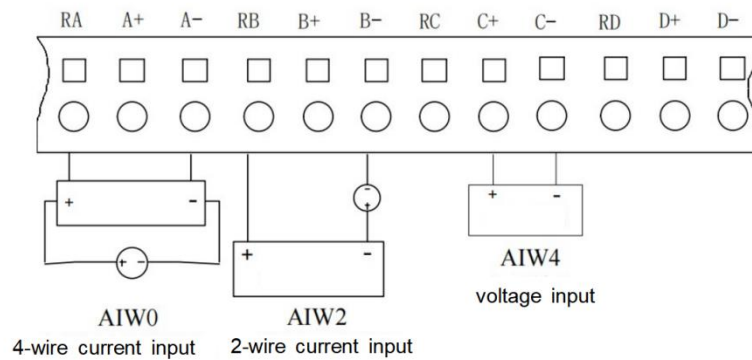

The CPU K606EA provides 4 groups of analog inputs, supporting both current and voltage inputs. For current signals, corresponds to connect *+ and *R (* represents the channel: A/B/C/D), while for voltage signals, the positive and negative terminals correspond to the connection *+ and *- (* represents the channel: A/B/C/D). When connecting a two-wire current transmitter (as shown in the AIW2), the transmitter signal+ is connected to the channel's sampling resistor "RA", while the transmitter signal- needs to be connected to channel "A-". When connecting a four-wire current transmitter (as shown in the AIW0), the transmitter signal- is connected to channel "B-", the transmitter signal+ is connected to RB, and the transmitter should be powered by external power supply. In the diagram, group C represents an example of voltage input, where the signal positive terminal corresponds to C+, and the signal negative terminal corresponds to C-.

If there are unused analog input channels in the CPU, it is recommended to short-circuit these channel terminals, and set the corresponding signal form in the KincoBuilder to [0-20mA] or [0-10V]. This practice artificially puts these channels in a signal acquisition state and dissipates

accumulated charges through short-circuiting to prevent interference-induced alarms. For example, if channel-D is not used, the three terminals of channel-D can be short-circuited. The short-circuiting method is shown in the diagram below:

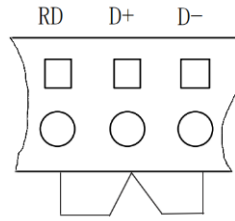

Symbol	Meaning	Symbol	Meaning
RA	ChannelA: sampling resistor	RB	ChannelB: sampling resistor
A+	ChannelA: input signal(+)	B+	ChannelB: input signal(+)
A-	ChannelA: input signal(-)	B-	ChannelB: input signal(-)
RC	ChannelC: sampling resistor	RD	ChannelD: sampling resistor
C+	ChannelC: input signal(+)	D+	ChannelD: input signal(+)
C-	ChannelC: input signal(-)	D-	ChannelD: input signal(-)

3.1.4.5 AO

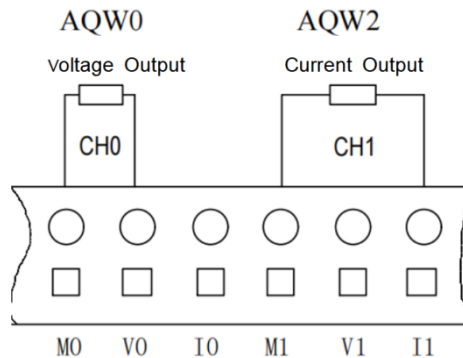

The CPU K606EA provides 2 channels of analog output, supporting both current and voltage signals. The symbols I, V, and M respectively correspond to current output, voltage output, and common terminal. For current output mode, connect the M and I pins, while for voltage output mode, connect the M and V pins.

In the diagram, the first group (AQW0) represents the wiring for voltage output. Connect the voltage output "V0" and the common terminal "M0" to the positive and negative terminals of the external device's analog input, respectively. The second group (AQW1) represents the wiring for current output. Connect the current output "I1" and the common terminal "M1" to the positive and negative terminals of the external device's analog input, respectively.

3.1.5 Wiring Diagrams

3.1.5.1 CPU K606

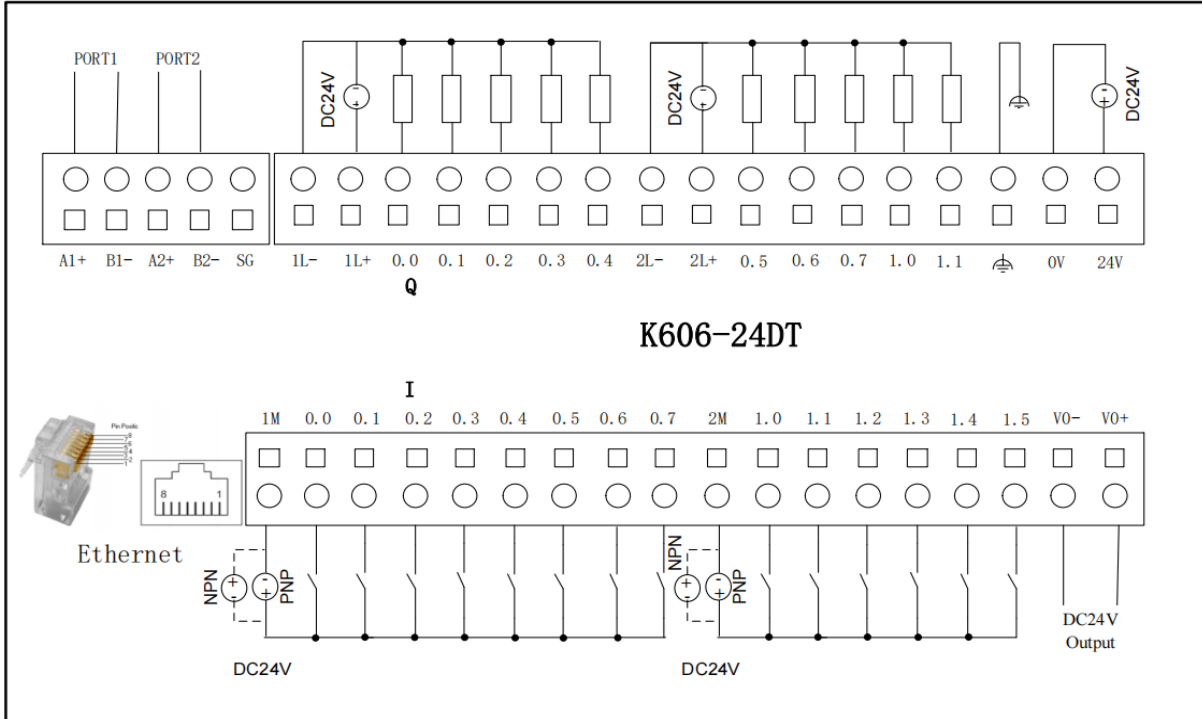

K606-24DT

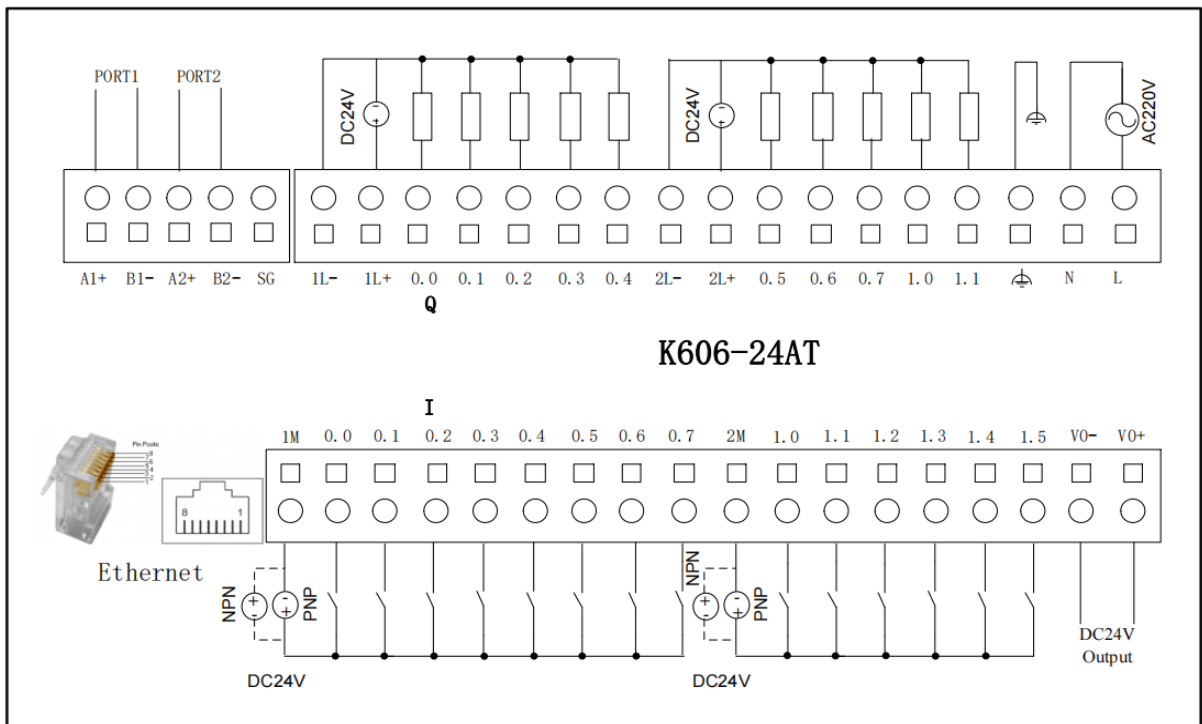

K606-24DT

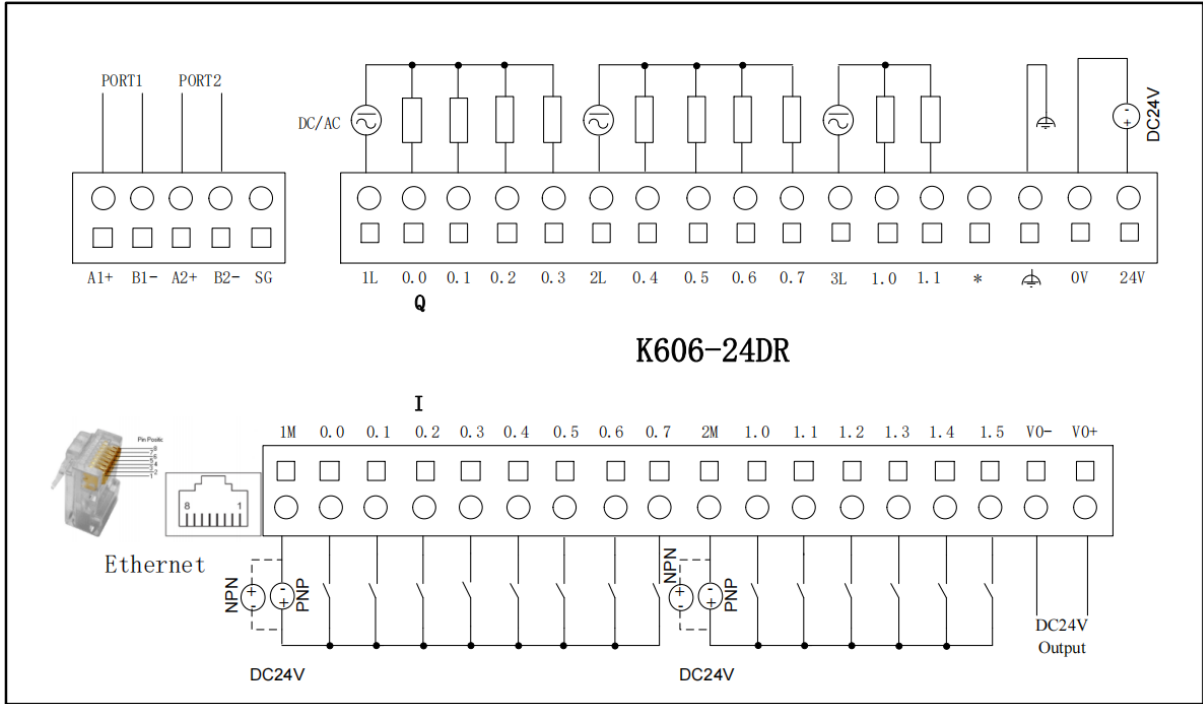

K606-24DR

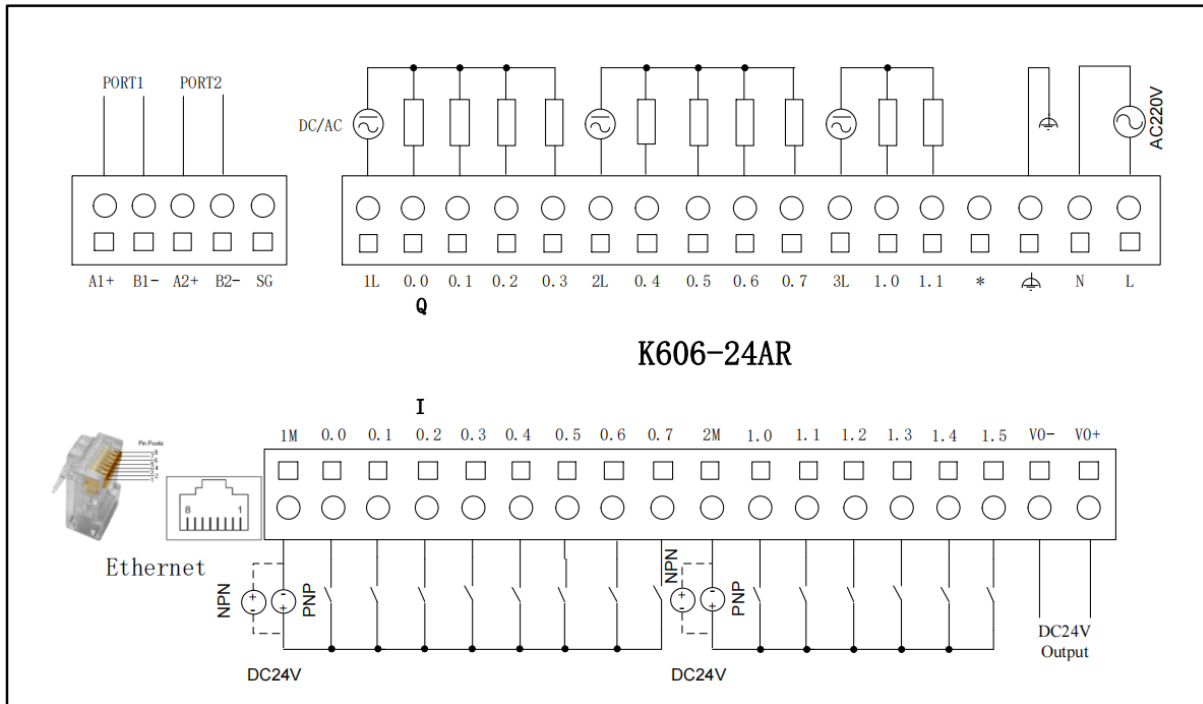

K606-24AR

3.1.5.2 CPU K608

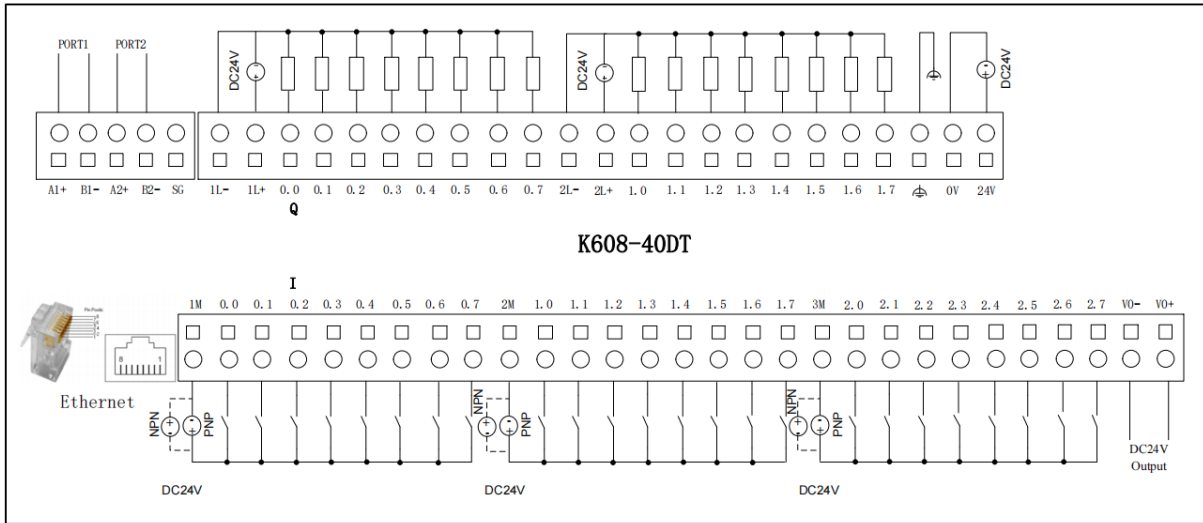

K608-40DT

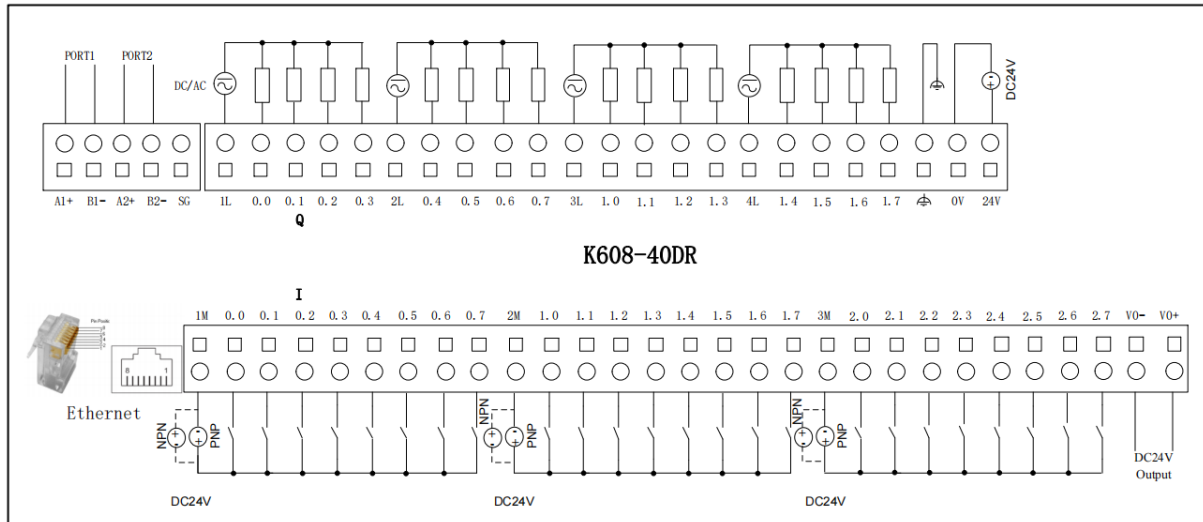

K608-40DR

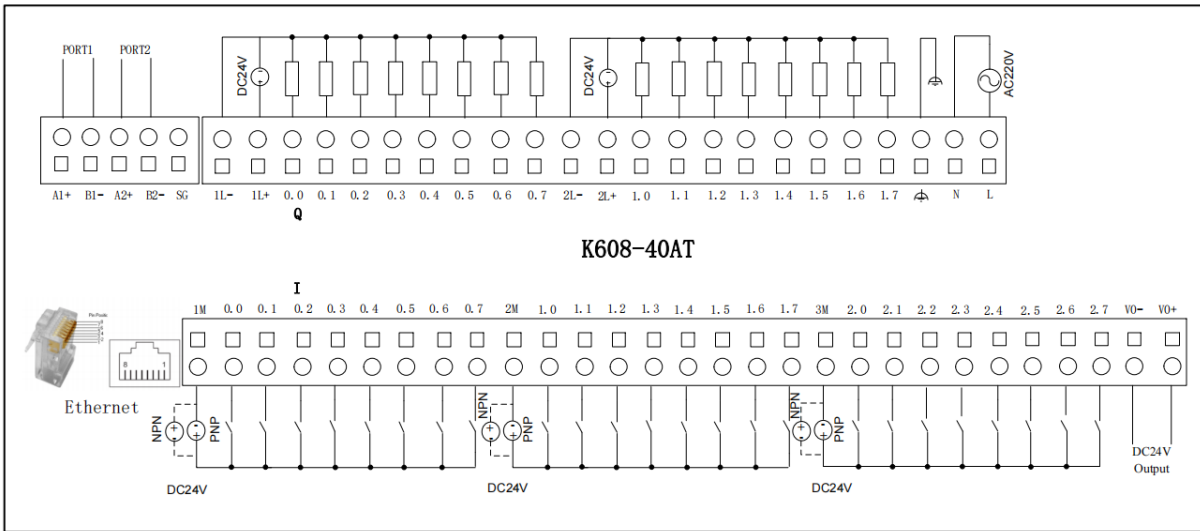

K608-40AT

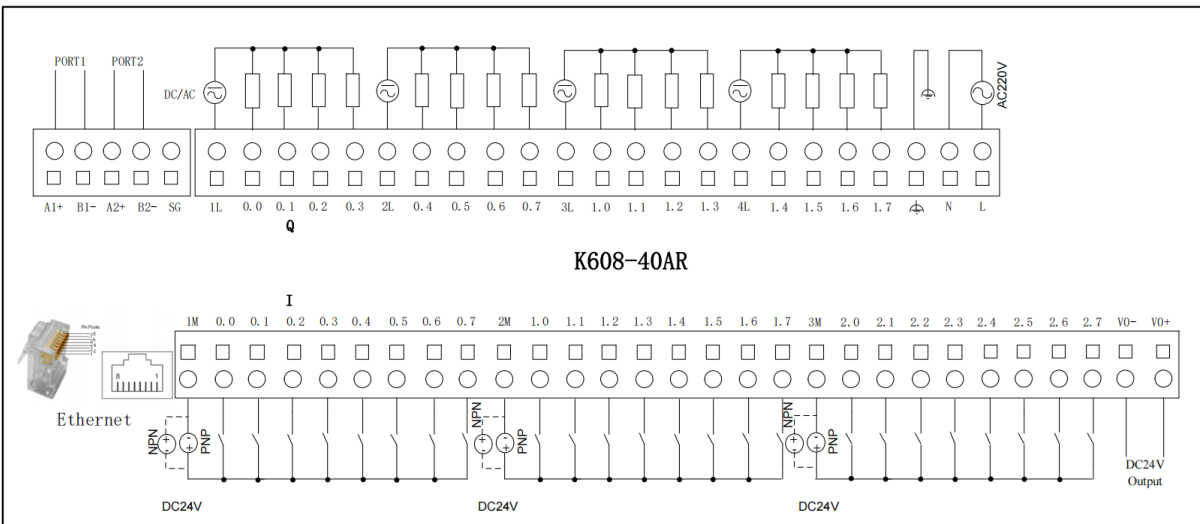

K608-40AR

3.1.5.3 CPU K606EA

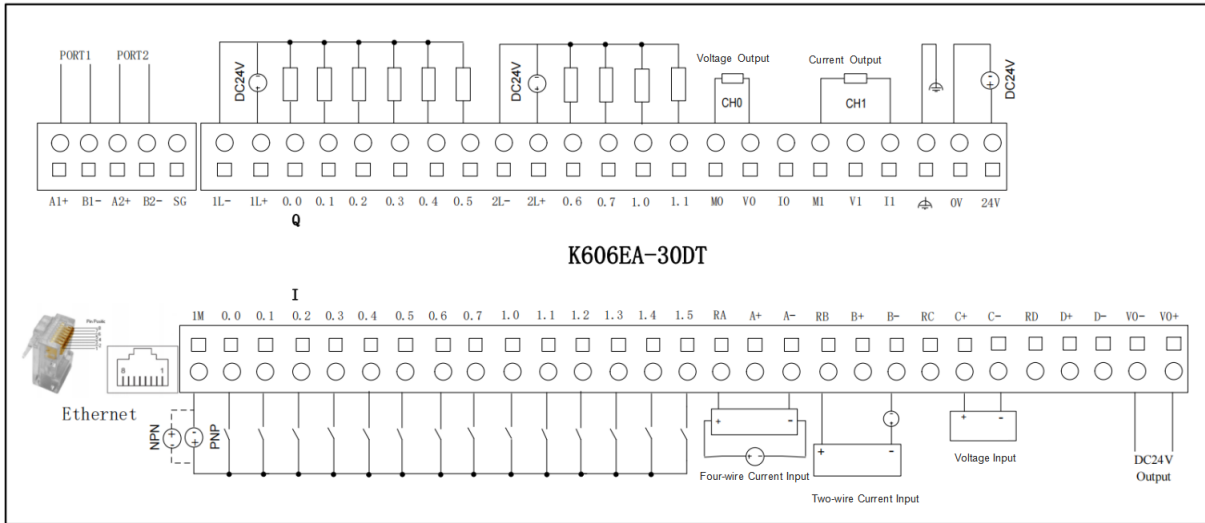

K606EA-30DT

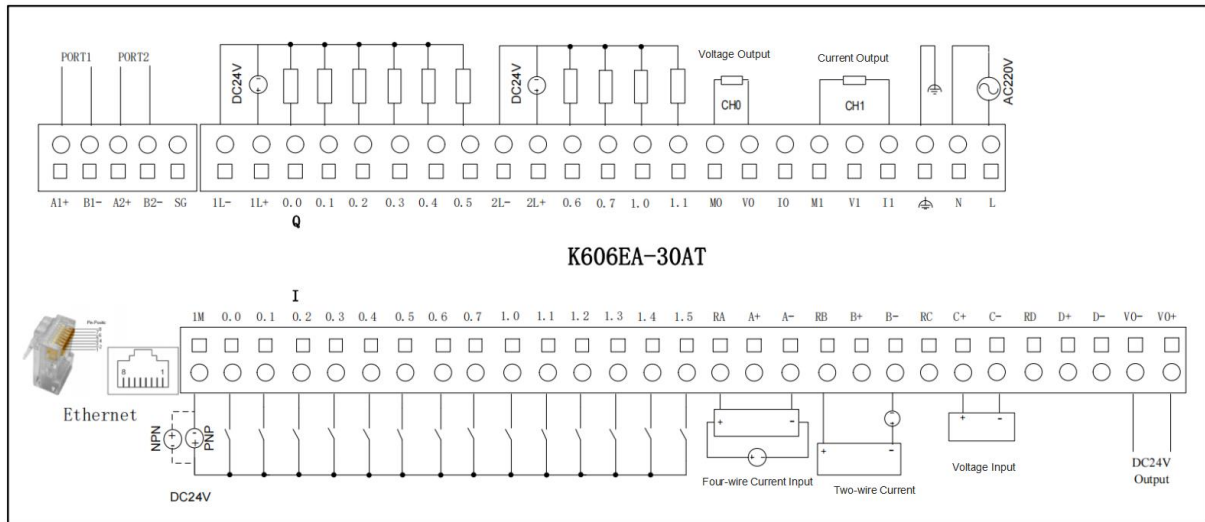

K606EA-30AT

3.2 BD Expansion

3.2.1 KB6-CAN

The K6 series CPU modules can expand CAN communication by connecting the KB6-CAN(BD0). For actual wiring, it is recommended to use a bus-type topology. To reduce signal reflections on the communication cables, it is suggested to add $120\ \Omega$ termination resistors at the beginning and end of the bus. For long distance communication, it is recommended to use shielded twisted pair cables for the communication cables, and ensure that the shielding layer is well grounded. Additionally, the cables should be kept away from strong sources of interference, such as high-power lines (including power cables of equipment) and pulse signal with high frequency.

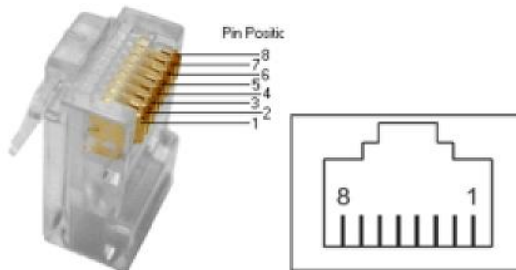

Pin	Signal	Description
1	CAN_H	CAN bus high-level signal (CAN High)
2	CAN_L	CAN bus low-level signal (CAN Low)
3	CAN_GND	CAN bus signal ground (CAN Ground)

The CAN bus topology is as shown in the diagram below. If there is a significant difference in common-mode voltage between nodes, it's recommended to connect all CAN_GND of the network nodes together to ensure that all nodes have a unified reference potential, thereby eliminating or reducing common-mode voltage and avoiding bus communication failures caused by common-mode interference. The communication distance of the CAN bus is inversely proportional to the communication rate. When the communication rate is 10kbps, the theoretical maximum communication distance is 1km; when the communication rate is 1Mbps, the theoretical maximum communication distance is 25m.

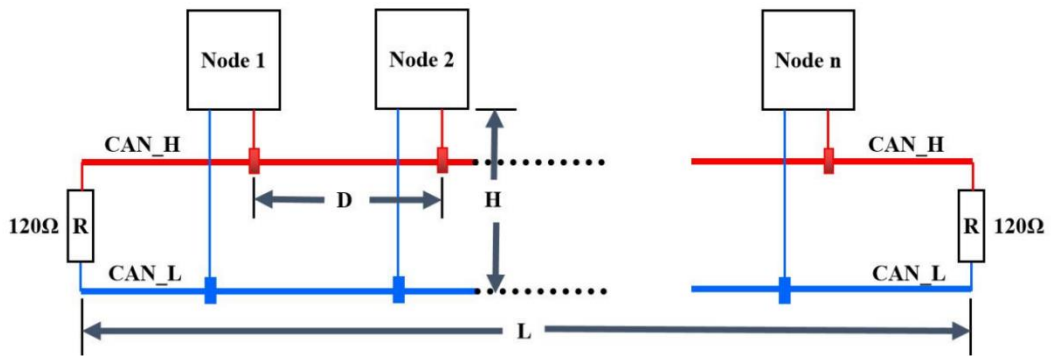

3.2.2 KB6-2COM

The K6 series CPU modules can expand 1 RS485 and 1 RS232 communication interface by the KB6-2COM module(BD0).

PORT0/PORT3

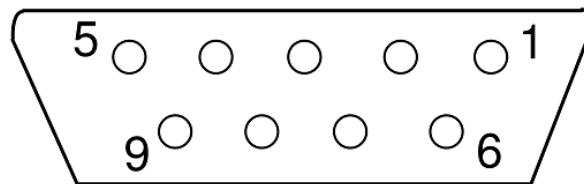

	Pin	Signal	Description
PORT0 (RS232)	2	RxD	Receive Data
	3	TxD	Transmit Data
	5	GND	Ground
PORT3 (RS485)	1	B	TXD-/B
	6	A	TXD+/A

3.2.3 KB6-4DI

The KB6-4DI provides 1 set of 4 transistor input channels(PNP/NPN).

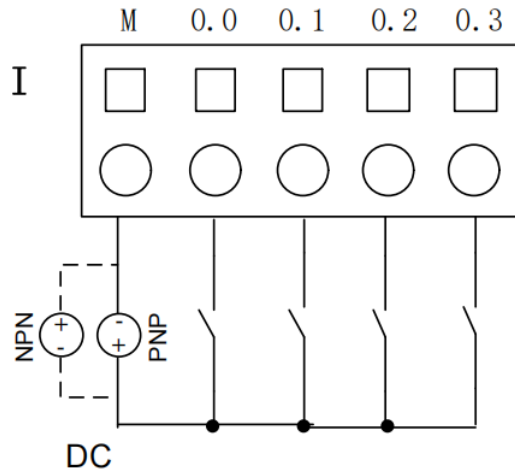

3.2.4 KB6-4DO

The KB6-4DO provides 4 channels of opto-relay type digital output. Each channel has a rated output current of 300mA, a maximum output current of 500mA, and channel short-circuit protection functionality.

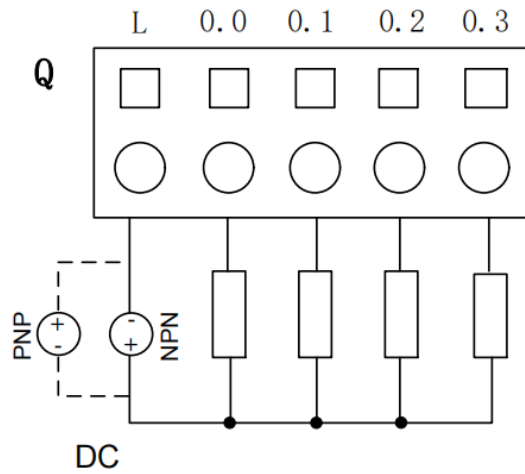

3.2.5 Wiring Diagram

DB6-CAN

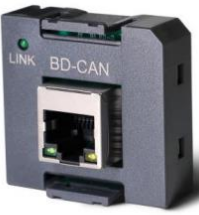

CAN2(Located in RJ45 port)

	PIN	Describe
CAN2	1	CAN_H
	2	CAN_L
	3	CAN_GND

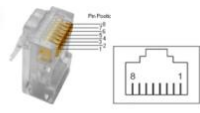

RJ45

DB6-2COM



	No.	Defintion	Describe
PORT0 (RS232)	2	RxD	Receive
	3	TxD	Trasmit
	5	GND	Ground
PORT3 (RS485)	1	B	RS485-
	6	A	RS485+

PORT0/PORT3

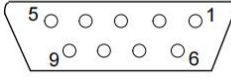

DB6-4DI



	M	0.0	0.1	0.2	0.3
I	□	□	□	□	□
	○	○	○	○	○

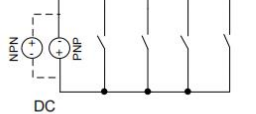

DC

DB6-4DO



	L	0.0	0.1	0.2	0.3
Q	□	□	□	□	□
	○	○	○	○	○

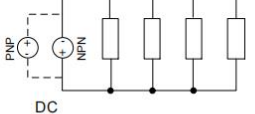

DC

3.3 Expansion Modules

3.3.1 K621-08DX

K621-08DX is a digital input module with 8 channels, including 2 sets (4 channels/set) of digital inputs.

- **Power Supply**

The modules are connected by the expansion bus, communicating via a special bus protocol from Kinco, and the module power supplies are already integrated in the expansion bus.

- **DI**

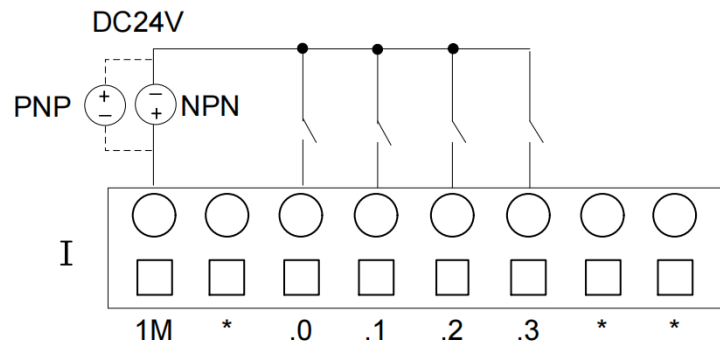

Taking the input common(1M) as reference, when the signal flows into the common (1M) from the input, it is referred to as NPN input. Conversely, when the signal flows out from the common(1M) at the input, it is referred to as NPN input. In the diagram, solid lines represent for PNP input, while dashed lines represent for PNP input.

● Diagram

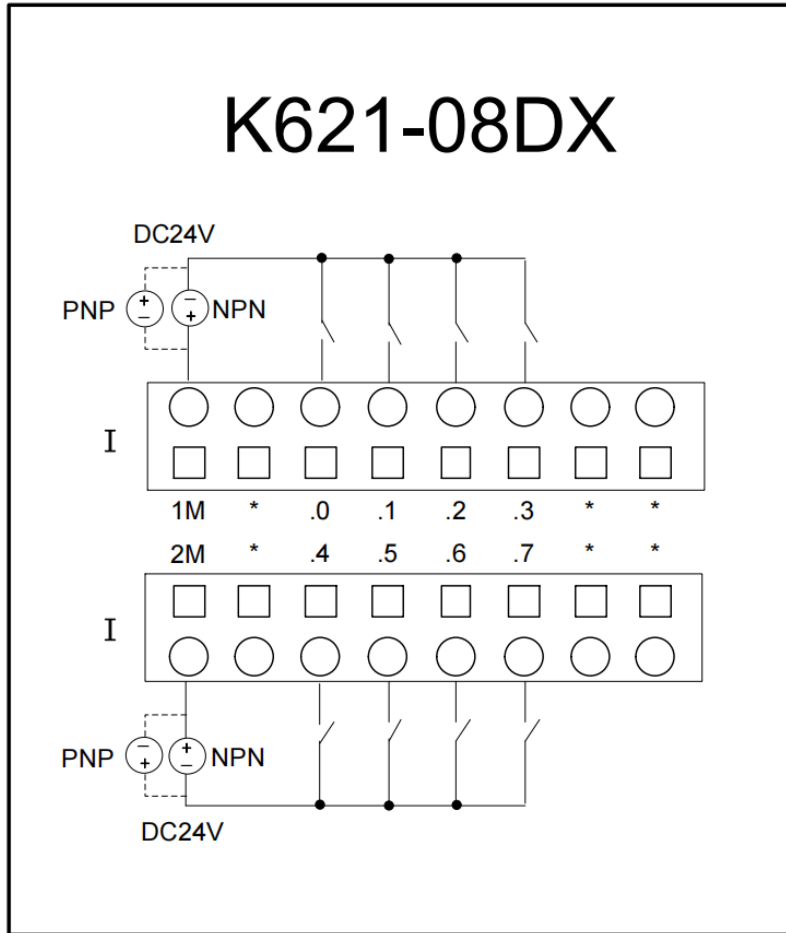

Symbol	Meaning	Symbol	Meaning
1M/2M	24V DC(+) (NPN)		
	24V DC(-) (PNP)		
*	Unconnected	.4	General Input
.0	General Input	.5	General Input
.1	General Input	.6	General Input
.2	General Input	.7	General Input
.3	General Input		

2.3.3 K621-16DX

- **Power Supply**

The modules are connected by the expansion bus, communicating via a special bus protocol from Kinco, and the module power supplies are already integrated in the expansion bus.

- **DI**

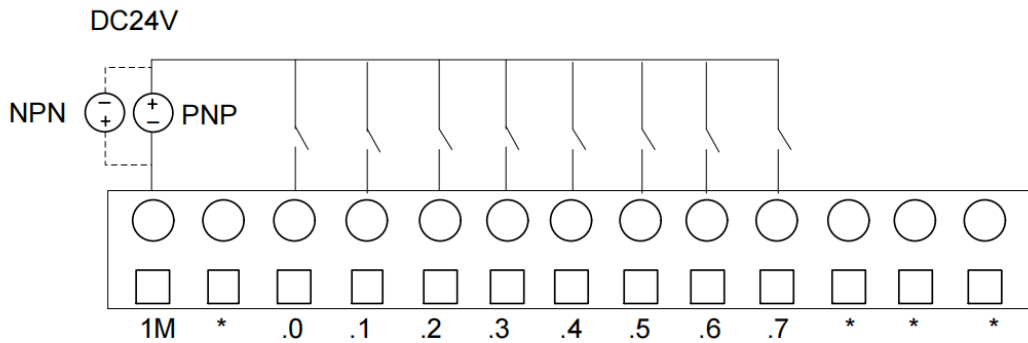

Taking the input common(1M) as reference, when the signal flows into the common (1M) from the input, it is referred to as NPN input. Conversely, when the signal flows out from the common(1M) at the input, it is referred to as PNP input. In the diagram, solid lines represent for PNP input, while dashed lines represent for NPN input.

● Diagram

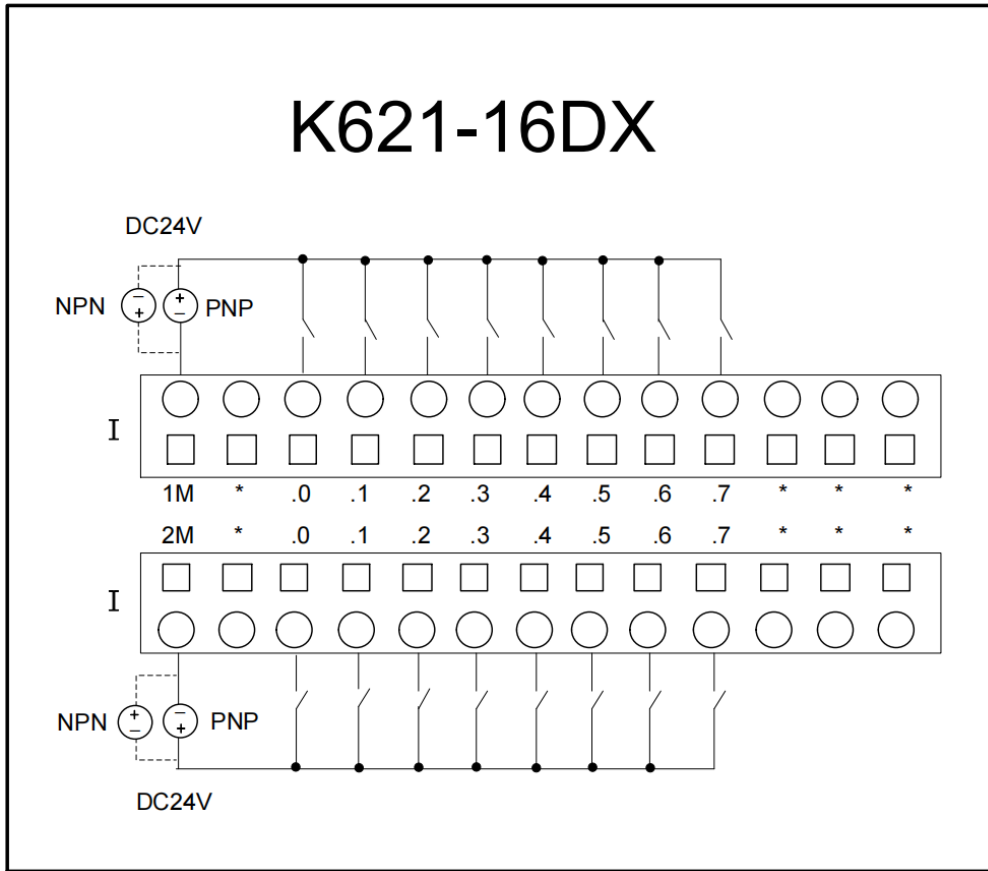

Symbol	Meaning	Symbol	Meaning
1M/2M	24V DC(+) (NPN)		
	24V DC(-) (PNP)		
*	Unconnected	.4	General Input
.0	General Input	.5	General Input
.1	General Input	.6	General Input
.2	General Input	.7	General Input
.3	General Input		

2.3.4 K622-08DT

K622-08DT is a transistor-type digital output module with 8 channels, including 2 sets(4 channels/set) of transistor outputs(PNP).

- **Power Supply**

The modules are connected by the expansion bus, communicating via a special bus protocol from Kinco, and the module power supplies are already integrated in the expansion bus.

- **DO**

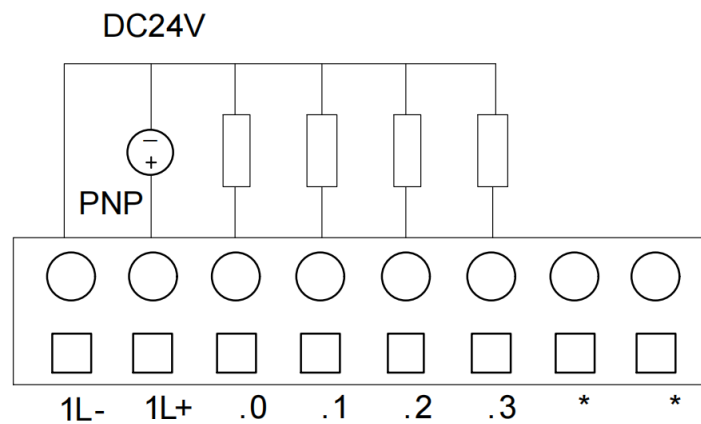

The K622-08DT supports only PNP output, which means that when a signal is triggered, the signal outputs a high level. The "1L+" and "1L-" pins connect to the positive and negative terminals of the DC24V power supply, respectively.

● Diagram

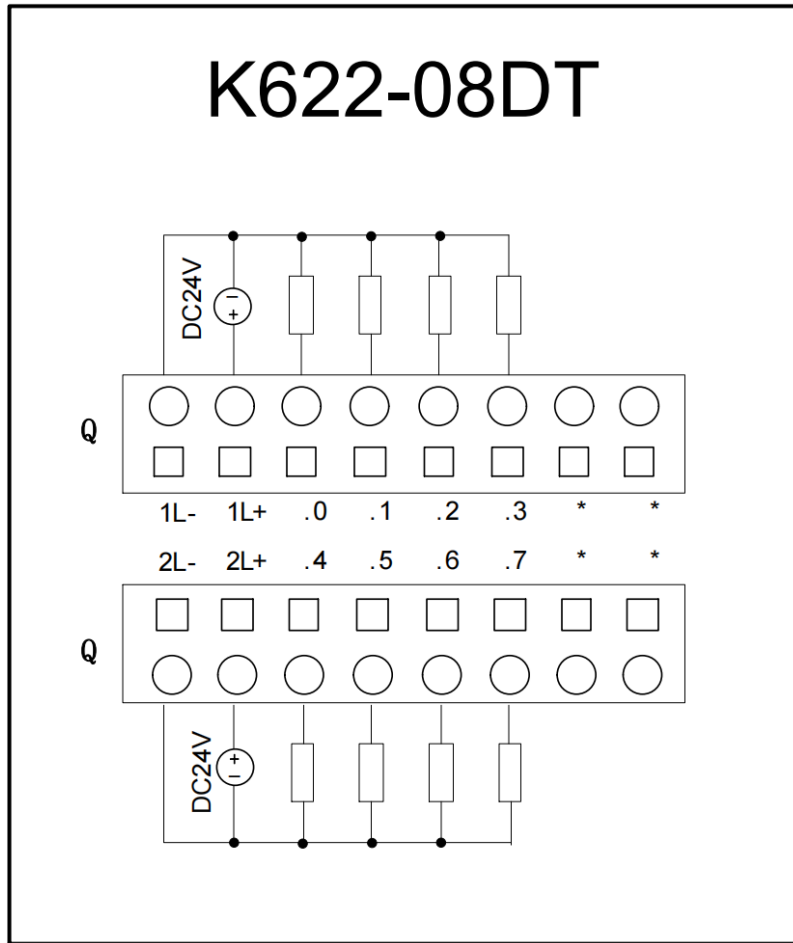

Symbol	Meaning	Symbol	Meaning
1L-/2L-	DC 24V-		
1L+/2L+	DC 24V+		
.0	General Output	.5	General Output
.1	General Output	.6	General Output
.2	General Output	.7	General Output
.3	General Output	*	Unconnected
.4	General Output		

2.3.5 K622-08XR

The K622-08XR is a output module with 8 channels, including 2 sets(4 channels/set) of relay outputs.

- **Power Supply**

The modules are connected by the expansion bus, communicating via a special bus protocol from Kinco, and the module power supplies are already integrated in the expansion bus.

- **DO**

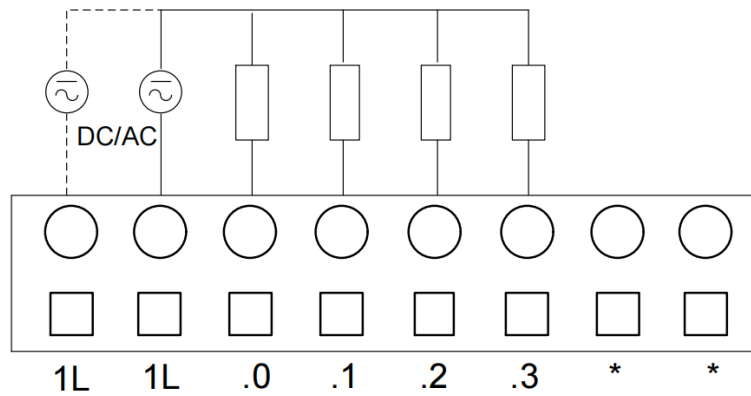

The diagram above illustrates the wiring for relay-type output. Each group of relay outputs is equipped with 2 power supply channels ("1L"), allowing the optional connection of either DC24V or AC220V. When the required current for the load is high, both channels("1L") should be connected to the power supply simultaneously to meet the output requirements.

● Diagram

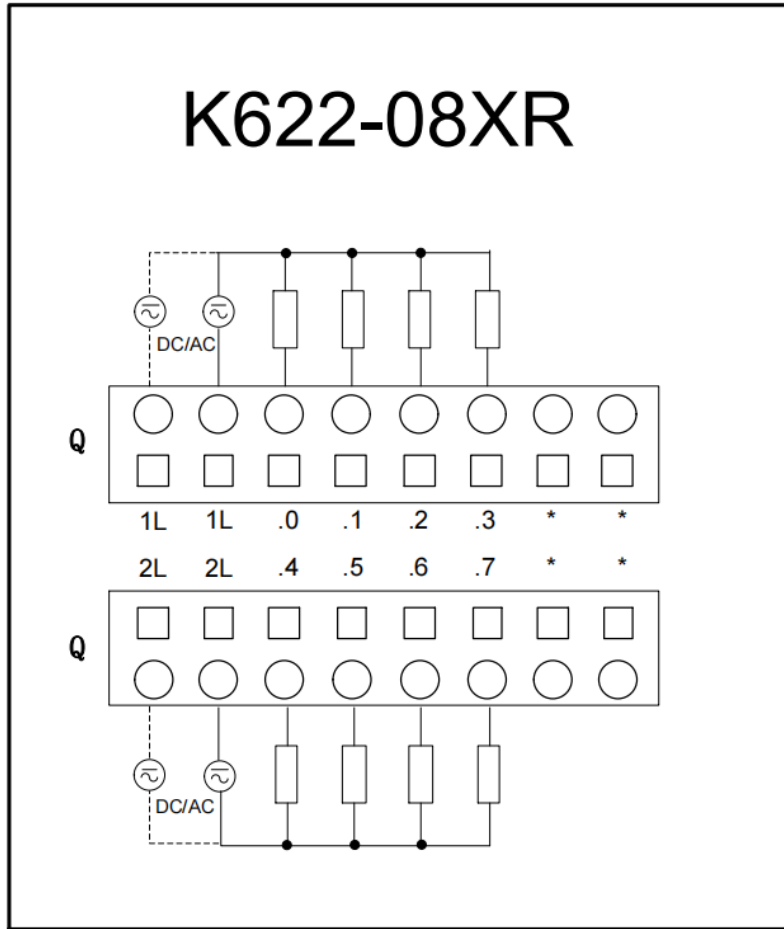

Symbol	Meaning	Symbol	Meaning
1L/2L	Power Supply (AC/DC)		
.0	Relay Output	.5	Relay Output
.1	Relay Output	.6	Relay Output
.2	Relay Output	.7	Relay Output
.3	Relay Output	*	Unconnected
.4	Relay Output		

2.3.6 K622-16DT

The K622-16DT is a transistor-type digital output module with 16 channels, including 4 sets(4 channels/set) of outputs(PNP).

- **Power Supply**

The modules are connected by the expansion bus, communicating via a special bus protocol from Kinco, and the module power supplies are already integrated in the expansion bus.

- **DO**

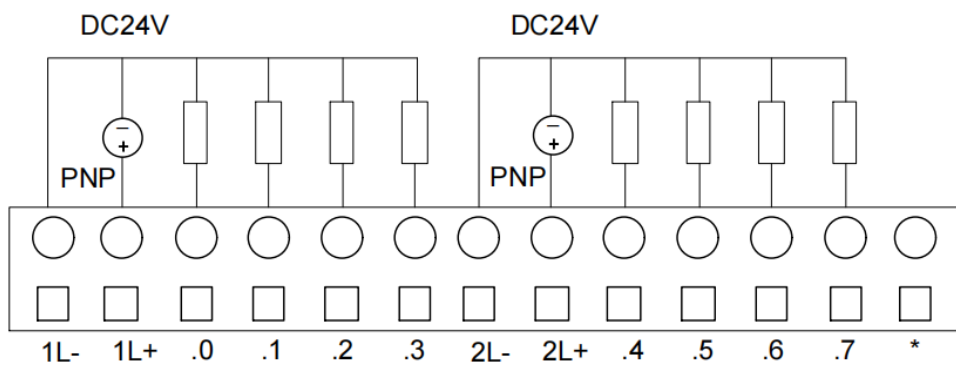

The K622-16DT supports only PNP output, which means that when a signal is triggered, the signal outputs a high level. The "1L+/2L+" and "1L-/2L-" pins connect to the positive and negative terminals of the DC24V power supply, respectively.

● Diagram

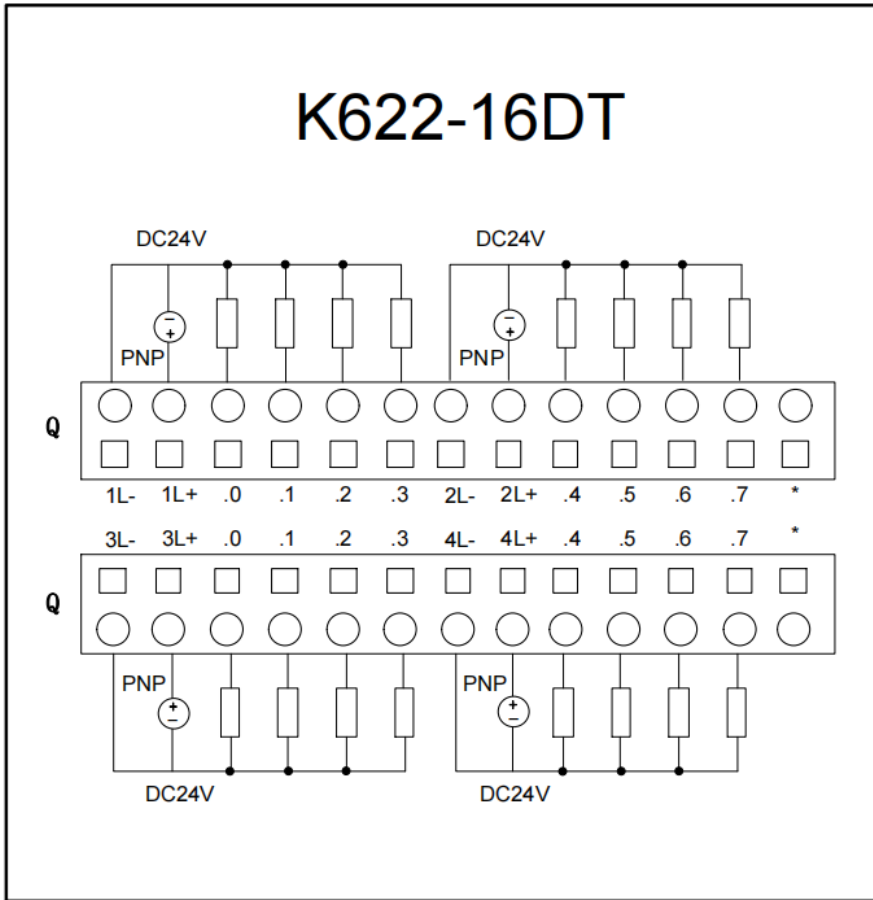

Symbol	Meaning	Symbol	Meaning
1L+/2L+/3L+/4L+	DC24V+		
1L-/2L-/3L-/4L-	DC24V-		
.0	General Output	.5	General Output
.1	General Output	.6	General Output
.2	General Output	.7	General Output
.3	General Output	*	Unconnected
.4	General Output		

2.3.7 K622-16XR

K622-16XR is a relay output module with 16 channels, including 4 sets(4 channels/set) of relay outputs.

- **Power Supply**

The modules are connected by the expansion bus, communicating via a special bus protocol from Kinco, and the module power supplies are already integrated in the expansion bus.

- **DO**

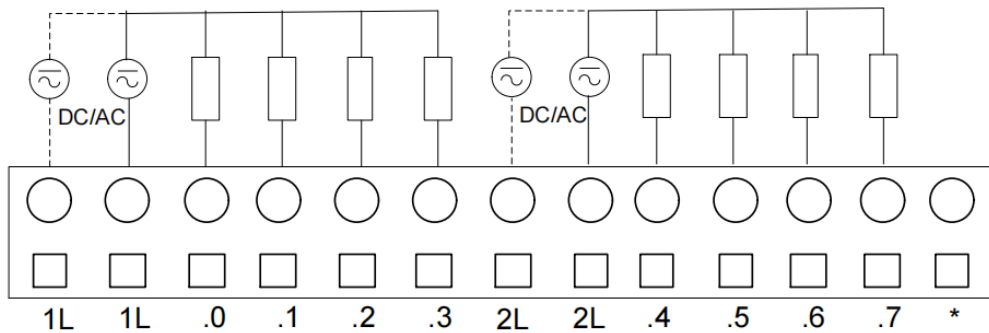

K622-16XR module has 4 sets(4 channels/set) of relay outputs. Each set has two external power supply input channels("L"), allowing the optional connection of either DC24V or AC220V. When the required current for the load is high, both channels("L") should be connected to the power supply simultaneously to meet the output requirements.

● Diagram

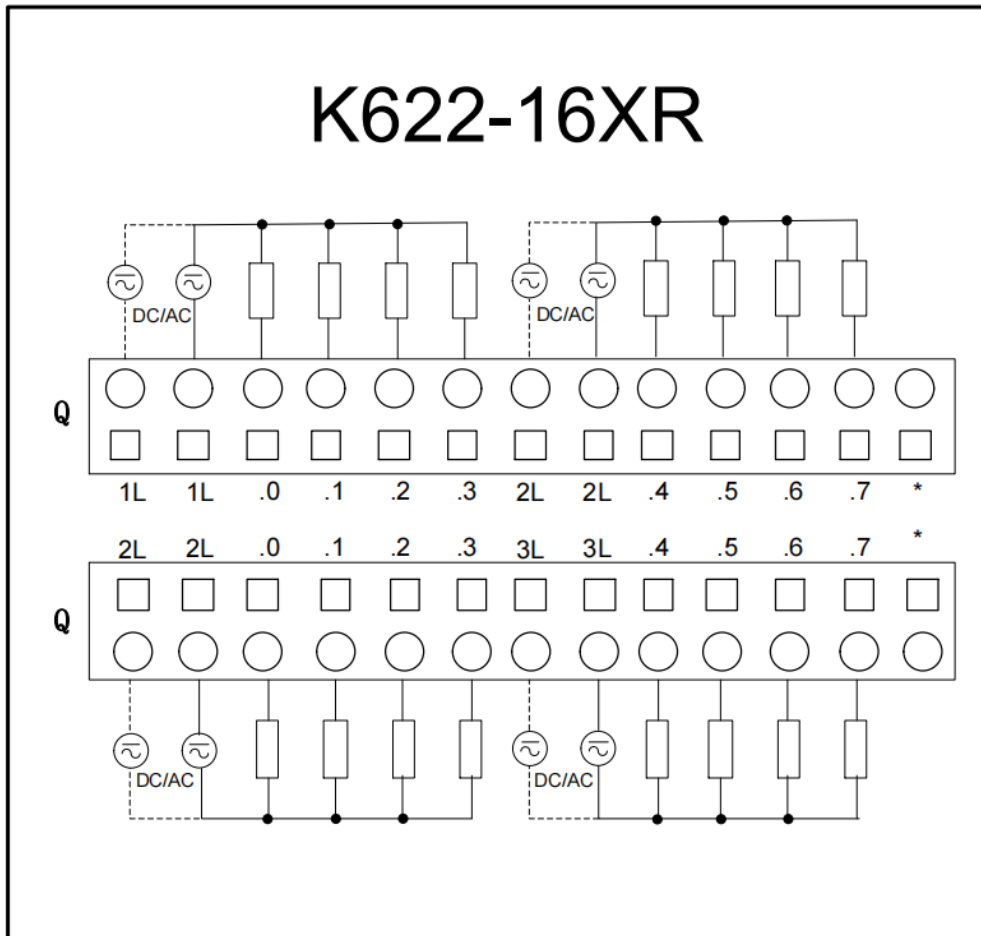

Symbol	Meaning	Symbol	Meaning
1L/2L/3L/4L	Power Supply DC/AC		
.0	Relay Output	.5	Relay Output
.1	Relay Output	.6	Relay Output
.2	Relay Output	.7	Relay Output
.3	Relay Output	*	Unconnected
.4	Relay Output		

2.3.8 K623-08DT

K623-08DT is a hybrid module with 8 channels, including 1 set of inputs (4 channels/set) and 1 set of PNP outputs (4 channels/set, transistor).

- **Power Supply**

The modules are connected by the expansion bus, communicating via a special bus protocol from Kinco, and the module power supplies are already integrated in the expansion bus.

- **DI**

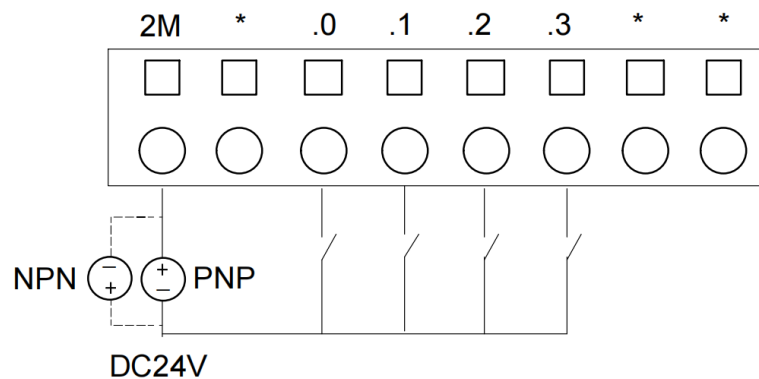

The above is a schematic diagram illustrating the wiring of the module's input section. Taking the input common(2M) as reference, when the signal flows into the common (2M) from the input, it is referred to as NPN input. Conversely, when the signal flows out from the common(2M) at the input, it is referred to as PNP input. In the diagram, solid lines represent for PNP input, while dashed lines represent for NPN input.

- **DO**

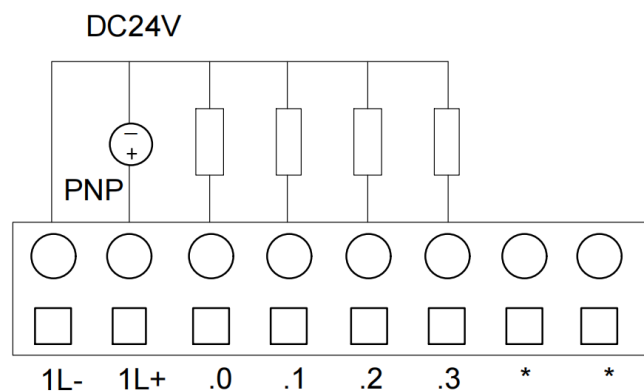

The diagram above illustrates the wiring schematic for the output section of the K623-08DT module. K623-08DT supports only PNP output, which means that when a signal is triggered, the signal outputs a high level. The "1L+" and "1L-" pins connect to the positive and negative terminals of the DC24V power supply, respectively.

● Diagram

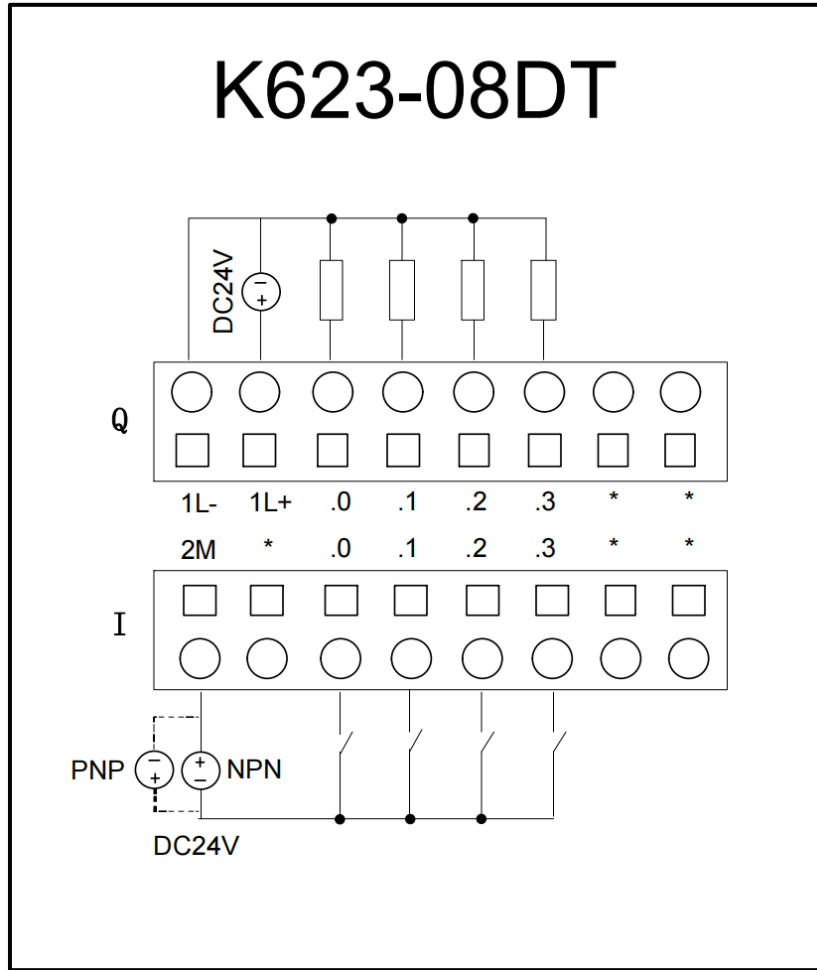

Symbol	Meaning	Symbol	Meaning
1L-	Power Supply 24V DC(+)		
1L+	Power Supply 24V DC(-)		
Output			
.0	General Output	.3	General Output
.1	General Output	*	Unconnected
.2	General Output		
Input			
2M	DI Common		
.0	General Input	.3	General Input
.1	General Input	*	Unconnected
.2	General Input		

2.3.9 K623-08DR

K623-08DR is a hybrid module with 8 channels, including 1 set of inputs (4 channels/set) and 1 set of relay outputs (4 channels/set).

- **Power Supply**

The modules are connected by the expansion bus, communicating via a special bus protocol from Kinco, and the module power supplies are already integrated in the expansion bus.

- **DI**

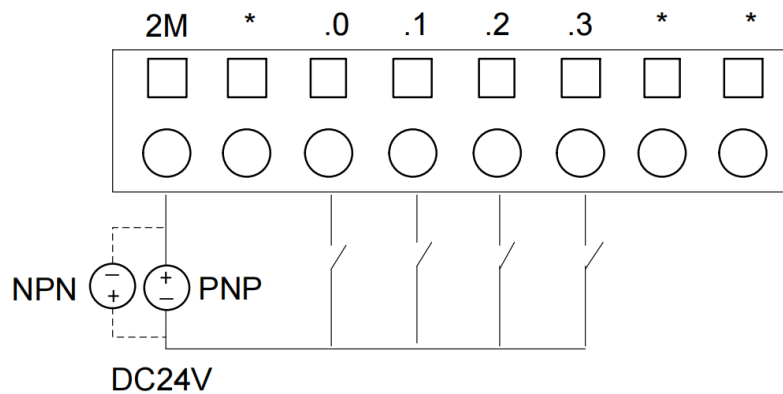

The above is a schematic diagram illustrating the wiring of the module's input section. Taking the input common(2M) as reference, when the signal flows into the common (2M) from the input, it is referred to as NPN input. Conversely, when the signal flows out from the common(2M) at the input, it is referred to as PNP input. In the diagram, solid lines represent for PNP input, while dashed lines represent for NPN input.

- **DO**

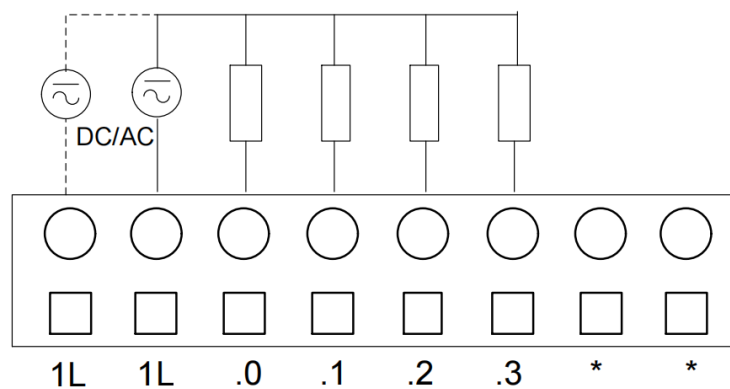

The K623-08DR has two external power supply input channels("L"), allowing the optional connection of either DC24V or AC220V. When the required current for the load is high, both channels("L") should be connected to the power supply simultaneously to meet the output requirements.

● Diagram

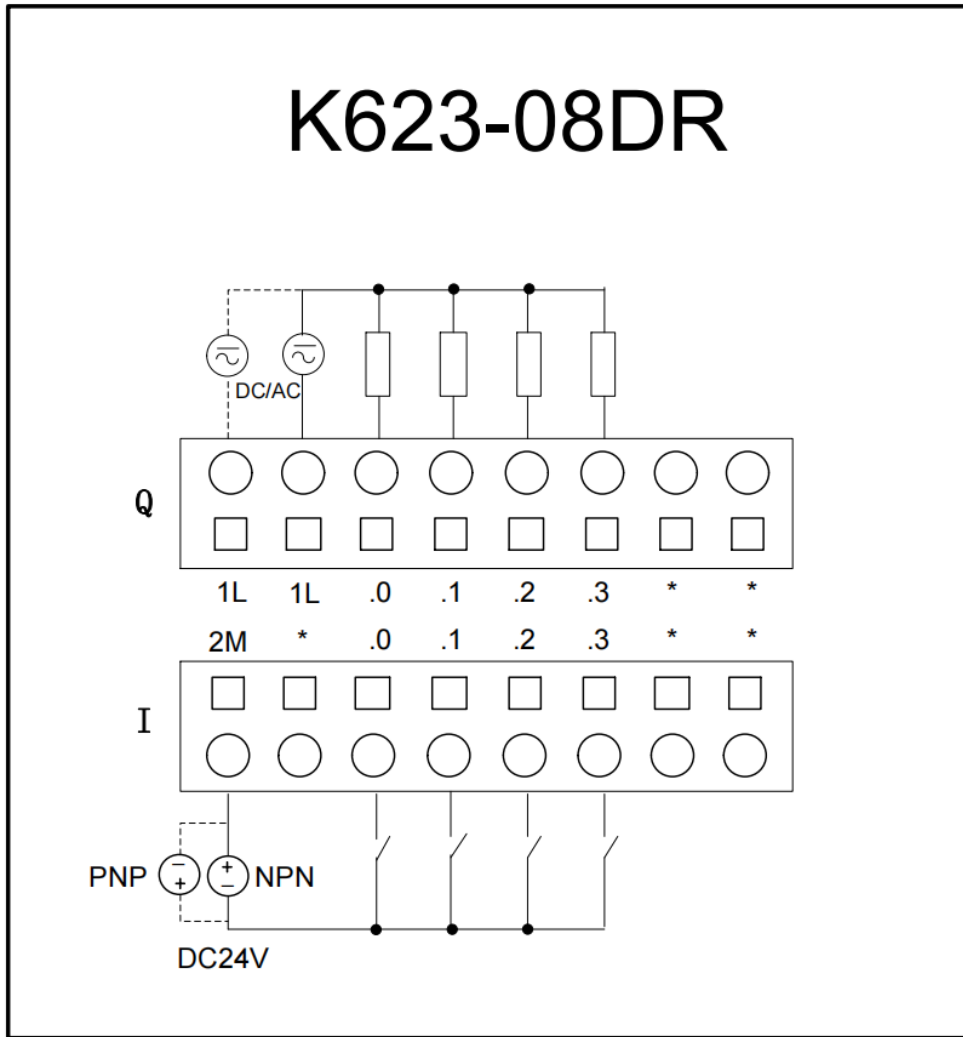

Symbol	Meaning	Symbol	Meaning
Output			
1L	Power Supply (DC/AC)		
.0	Relay Output	.3	Relay Output
.1	Relay Output	*	Unconnected
.2	Relay Output		
Input			
2M	DI Common		
.0	General Input	.3	General Input
.1	General Input	*	Unconnected
.2	General Input		

2.3.10 K623-16DT

K623-16DT is a hybrid module with 16 channels of digital input and digital output. It includes 2 sets (4 channels/set) of inputs and 2 sets (4 channels/set) of PNP-type outputs(transistor).

- **Power Supply**

The modules are connected by the expansion bus, communicating via a special bus protocol from Kinco, and the module power supplies are already integrated in the expansion bus.

- **DI**

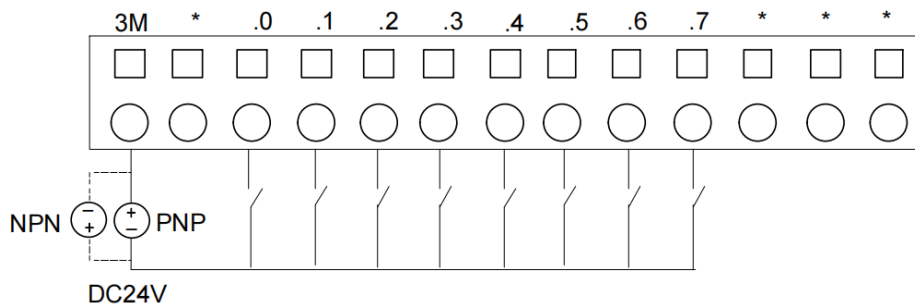

The above is a schematic diagram illustrating the wiring of the module's input section. Taking the input common(3M) as reference, when the signal flows from the common (3M), it is referred to as NPN input. Conversely, when the signal flows out from the common(3M) at the input, it is referred to as PNP input. In the diagram, solid lines represent for PNP input, while dashed lines represent for NPN input.

- **DO**

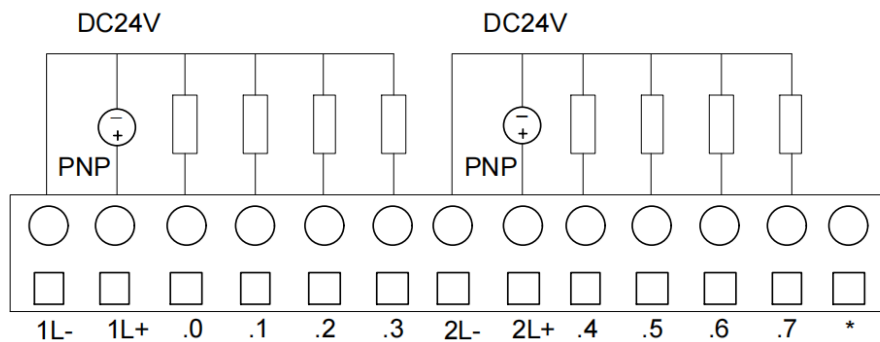

The K623-16DT supports only PNP output, which means that when a signal is triggered, the signal outputs a high level. The "1L+" and "1L-" pins connect to the positive and negative terminals of the DC24V power supply, respectively.

● Wiring Diagram

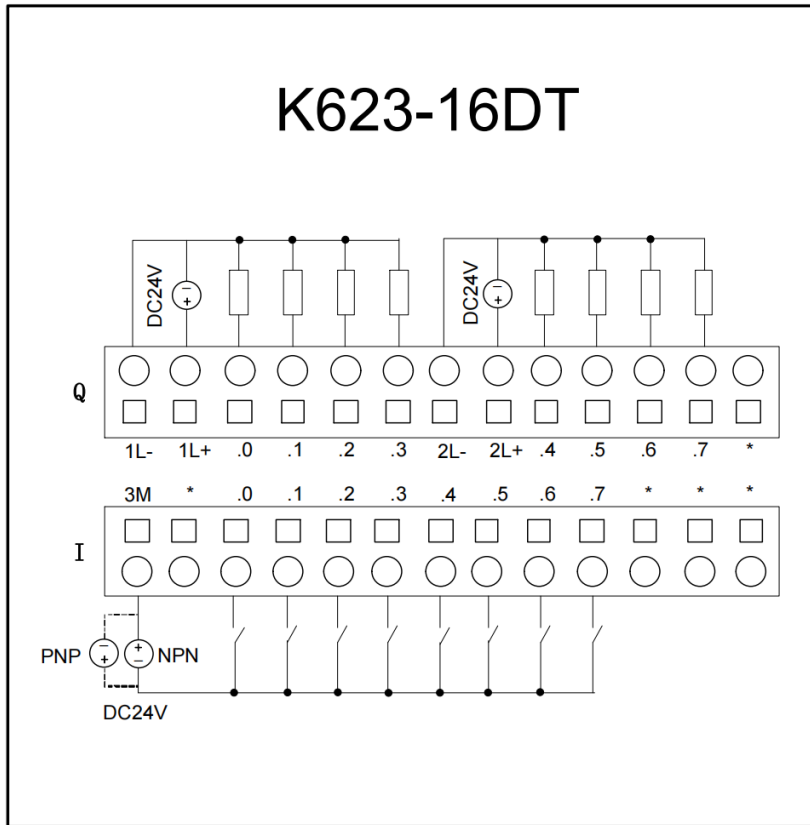

Symbol	Meaning	Symbol	Meaning
Input			
3M	DI Common		
.0	General Input	.5	General Input
.1	General Input	.6	General Input
.2	General Input	.7	General Input
.3	General Input	*	Unconnected
.4	General Input		
Output			
1L-/2L-	Power Supply 24V DC(+)		
1L+/2L+	Power Supply 24V DC(-)		
.0	General Output	.5	General Output
.1	General Output	.6	General Output
.2	General Output	.7	General Output
.3	General Output	*	Unconnected
.4	General Output		

2.3.11 K623-16DR

The K623-16DR is a hybrid module with 16 channels, including 1 set of digital input (8 channels/set) and 2 sets of relay output (4 channels/set).

- **Power Supply**

The modules are connected by the expansion bus, communicating via a special bus protocol from Kinco, and the module power supplies are already integrated in the expansion bus.

- **DI**

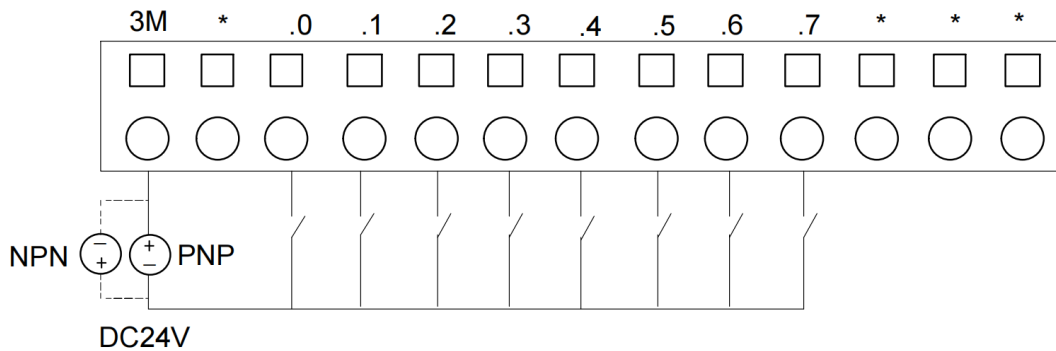

The above is a schematic diagram illustrating the wiring of the module's input section. Taking the input common(3M) as reference, when the signal flows from the common (3M), it is referred to as NPN input. Conversely, when the signal flows out from the common(3M) at the input, it is referred to as PNP input. In the diagram, solid lines represent for PNP input, while dashed lines represent for NPN input.

- **DO**

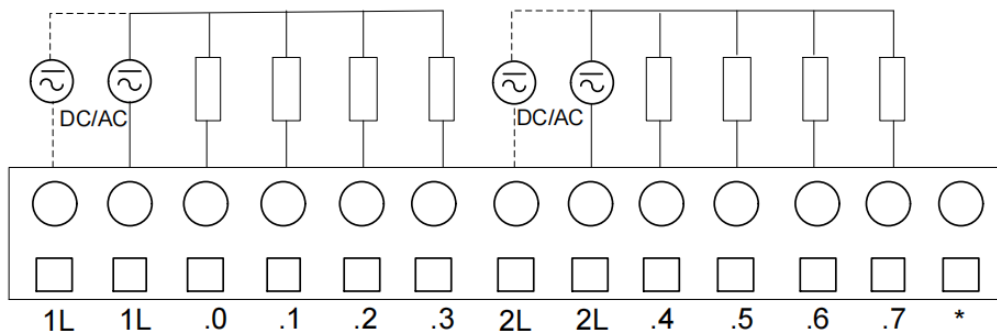

The output channels of the K623-16DR are divided into two groups, each with two power supply input channels. When a large output current is required, please connect both sets of power supply channels simultaneously. In general, it is sufficient to connect one of them for normal operation.

● Wiring Diagram

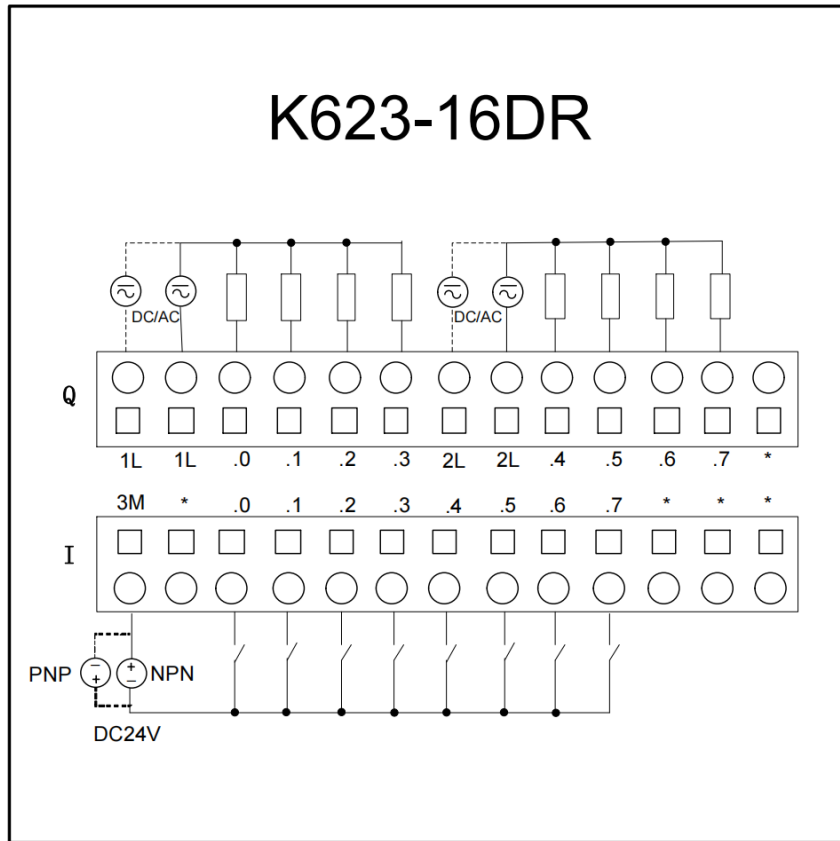

Symbol	Meaning	Symbol	Meaning
Input			
3M	DI Common		
.0	General Input	.6	General Input
.1	General Input	.7	General Input
.2	General Input	*	Unconnected
.3	General Input		
.4	General Input		
.5	General Input		
Output			
1L/2L	Power Supply (DC/AC)		
.0	Relay Output	.5	Relay Output
.1	Relay Output	.6	Relay Output
.2	Relay Output	.7	Relay Output
.3	Relay Output	*	Unconnected
.4	Relay Output		

2.3.12 K631-04IV

The K631-04IV has 4 analog input channels and supports the measurement of voltage or current signals within the range of 4~20mA, 1~5V, 0~20mA, and 0~10V.

- **Power Supply**

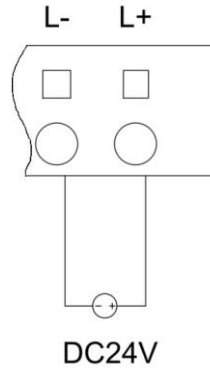

Symbol	Meaning
24V	Power Supply(24V DC+)
0V	Power Supply(24V DC-)

In addition to being powered by the expansion bus, the K631-04IV module also requires an additional connection to DC24V to drive external circuits.

- **Voltage Input**

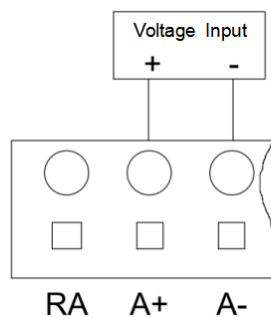

All four analog input channels of the K631-04IV module support voltage input measurement. The input signal corresponds to connection pins *+ and *- (* represents the channel : A/B/C/D).

● **Current Input**

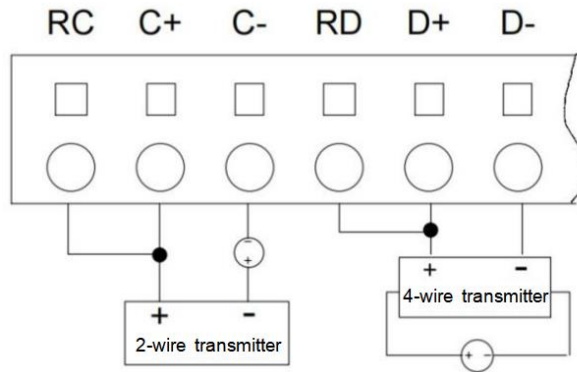

All four analog input channels of the K631-04IV support two-wire or three-wire current input measurement. The transmitter signal corresponds to connection pins *+ and *- (* represents the channel: A/B/C/D), and the positive of the transmitter also needs to be connected to "R". For four-wire current signals, the transmitter also needs to be powered by 24V DC. As shown in the diagram, the left side depicts the connection for two-wire current input, while the right side depicts the connection for four-wire current input.

● **Short-circuit**

If there are unused channels in the module, it is recommended to short-circuit those channels to prevent interference from causing erroneous measurements. Taking the channel-D as an example, when short-circuiting, it is only necessary to short-circuit all three segments of the same channel together.

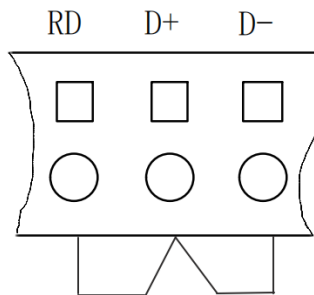

● Wiring Diagram

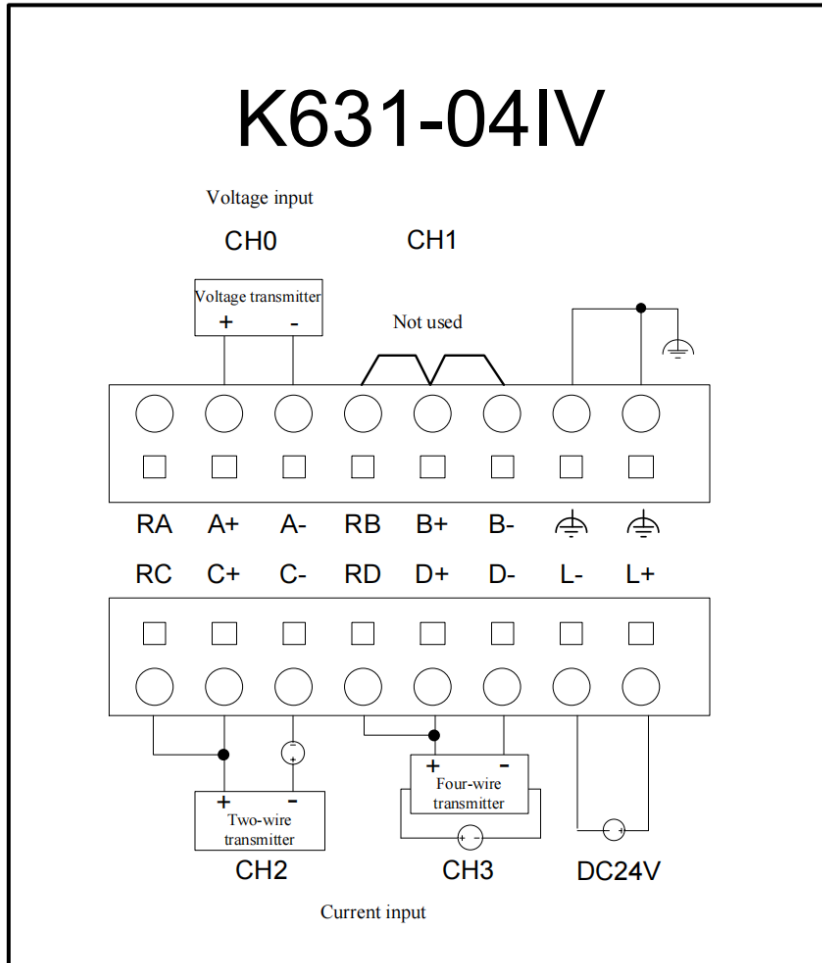

Symbol	Meaning	Symbol	Meaning
RA	ChannelA: sampling resistor	RB	ChannelB: sampling resistor
A+	ChannelA: input signal(+)	B+	ChannelB: input signal(+)
A-	ChannelA: input signal(-)	B-	ChannelB: input signal(-)
RC	ChannelC: sampling resistor	RD	ChannelD: sampling resistor
C+	ChannelC: input signal(+)	D+	ChannelD: input signal(+)
C-	ChannelC: input signal(-)	D-	ChannelD: input signal(-)
L+	Power Supply DC24V(+)	⏏	Ground
L-	Power Supply DC24V(-)		

2.3.13 K631-04TC

The K631-04TC module provides 4 measurement channels, all supporting J-type, K-type, E-type, and S-type thermocouple measurements. The compensation modes include both cold junction internal compensation and external compensation.

Note: Since the temperature sensing element of the cold junction is installed inside the module, selecting internal compensation will result in the measurement being affected by the heat generated during module operation. Typically, measurements by internal compensation will be approximately 2~4℃ higher than the actual temperature.

- **Power Supply**

The modules are connected by the expansion bus, communicating via a special bus protocol from Kinco, and the module power supplies are already integrated in the expansion bus.

- **Thermocouple Input**

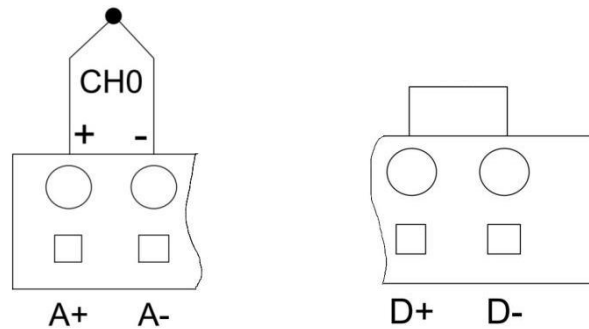

The K631-04TC module supports 4-channel of thermocouple measurement. The symbol "+" and "-" (* represents channel : A/B/C/D) correspond to connecting the positive and negative poles of the thermocouple(refer to the diagram above on the left-side). It is recommended to short-circuit the channels that are not needed to prevent measurement errors caused by interference(refer to the diagram above on the right-side).

- **Ground**

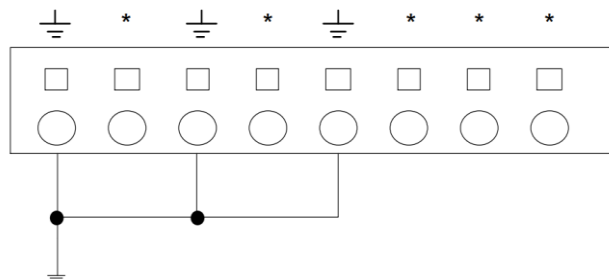

Please refer to the above diagram to connect the ground to improve the immunity to common-mode interference.

● Wiring Diagram

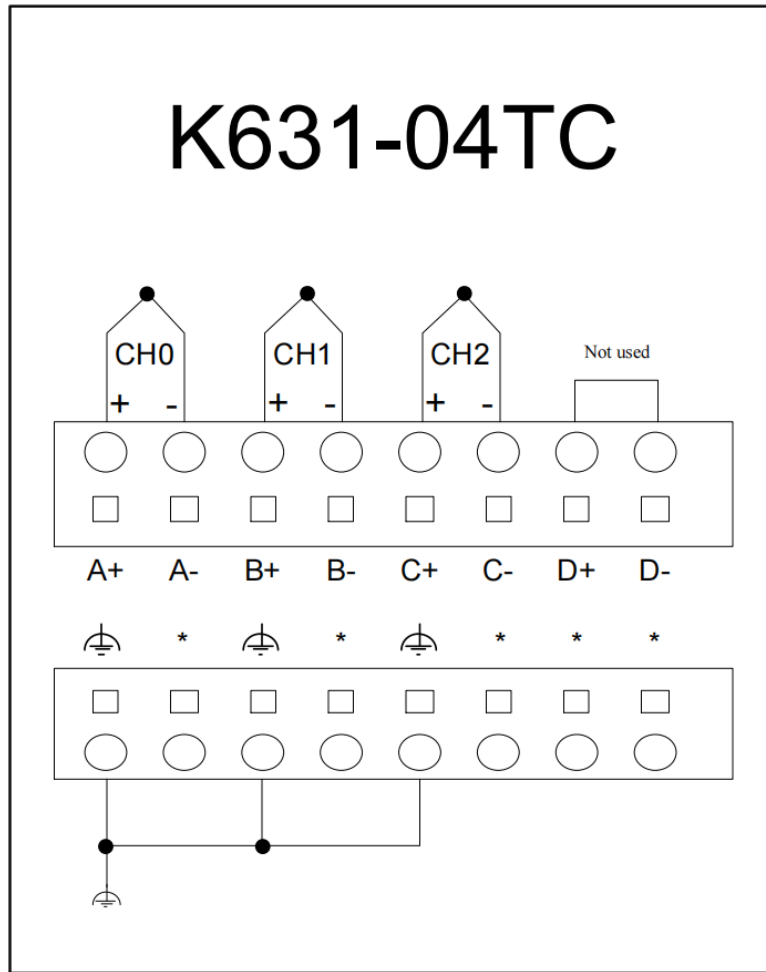

Symbol	Meaning	Symbol	Meaning
A+	Channel-A:thermocouple(+)	B+	Channel-B:thermocouple(+)
A-	Channel-A:thermocouple(-)	B-	Channel-B:thermocouple(-)
C+	Channel-C:thermocouple(+)	D+	Channel-D:thermocouple(+)
C-	Channel-C:thermocouple(-)	D-	Channel-D:thermocouple(-)
⏏	Ground	*	Unconnected

2.3.14 K631-04RD

The K631-04RD module has 4 sets of resistance temperature detector (RTD) measurement channels, supporting Pt100, Pt1000, Cu50 type(two-wire or three-wire) temperature measurements, and also supports direct measurement of resistance values.

- **Power Supply**

The modules are connected by the expansion bus, communicating via a special bus protocol from Kinco, and the module power supplies are already integrated in the expansion bus.

- **AI**

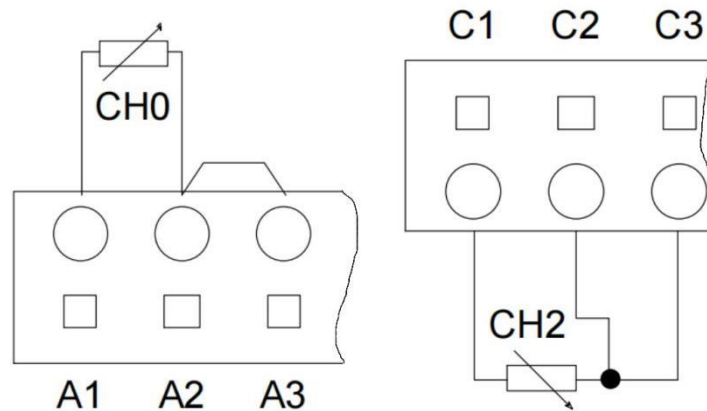

The K631-04RD provides 4 channels for thermocouple measurement, with each set having three terminals labeled "*1", "*2", and "*3" (* corresponds to channel:A/B/C/D). It is recommended for users to short-circuit the unused channels to prevent interference from causing false measurements or alarms. The short-circuit method is shown in the diagram below.

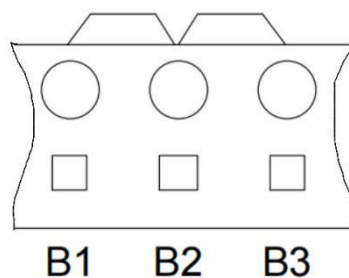

● Wiring Diagram

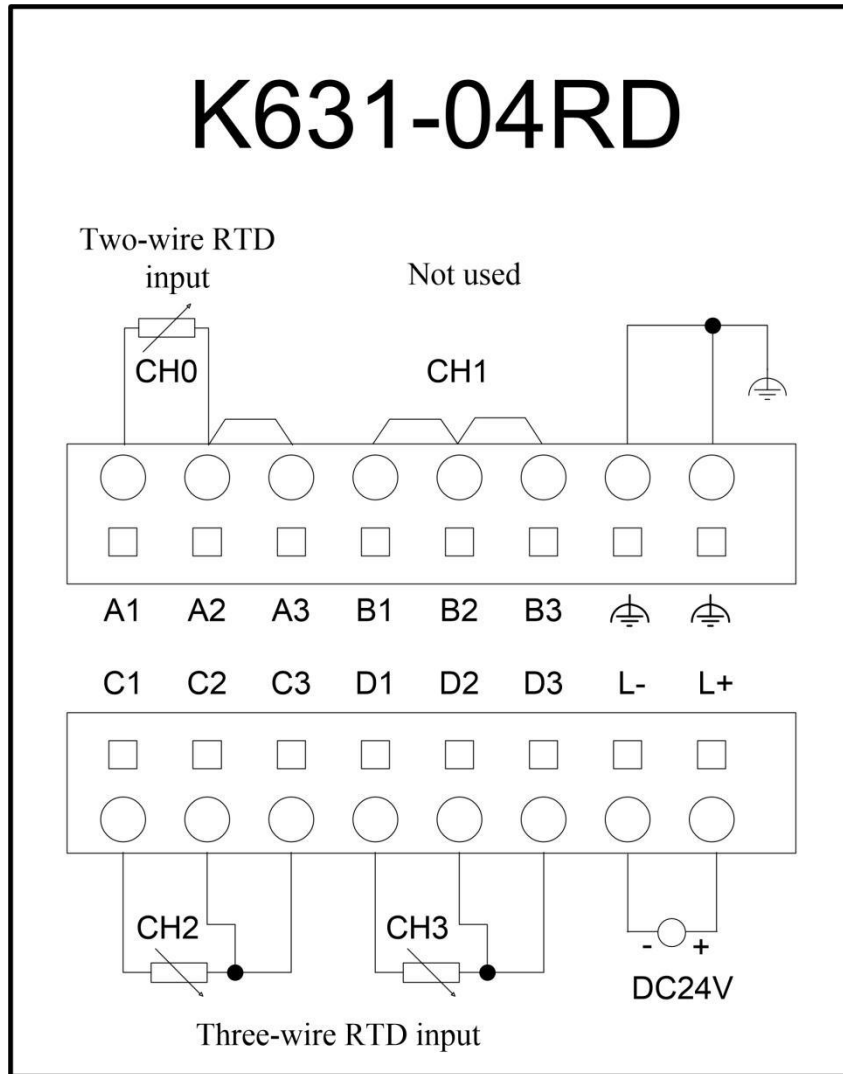

Symbol	Meaning	Symbol	Meaning
A1	Channel-A	B1	Channel-B
A2		B2	
A3		B3	
C1	Channel-C	D1	Channel-D
C2		D2	
C3		D3	
L+	Power Supply DC24V(+)		Ground
L-	Power Supply DC24V(-)		

2.3.15 K632-02IV

The K632-02IV module provides two analog output channels, supporting current and voltage outputs, all of them support voltage or current signals (4~20mA, 1~5V, 0~20mA, 0~10V).

- Power Supply

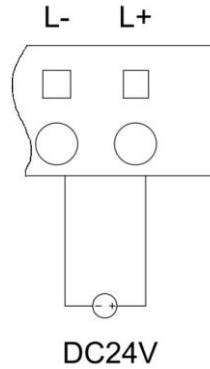

Symbol	Meaning
24V	Power Supply(24V DC+)
0V	Power Supply(24V DC-)

In addition to being powered by the expansion bus, the K632-02IV module also requires an additional connection to DC24V to drive external circuits.

- AO

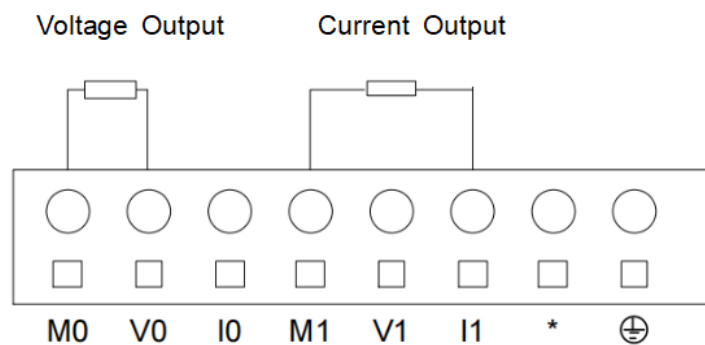

The K633-04IV module provides two analog output channels, supporting current and voltage outputs. The I, V, and M symbols correspond to the current output, voltage output, and common terminal respectively. For voltage output, connect to "V*" and common "M*" (* refers to channel 0/channel1); for current output, connect to "I*" and common "M*" (* refers to channel0/channel1).

● Wiring Diagram

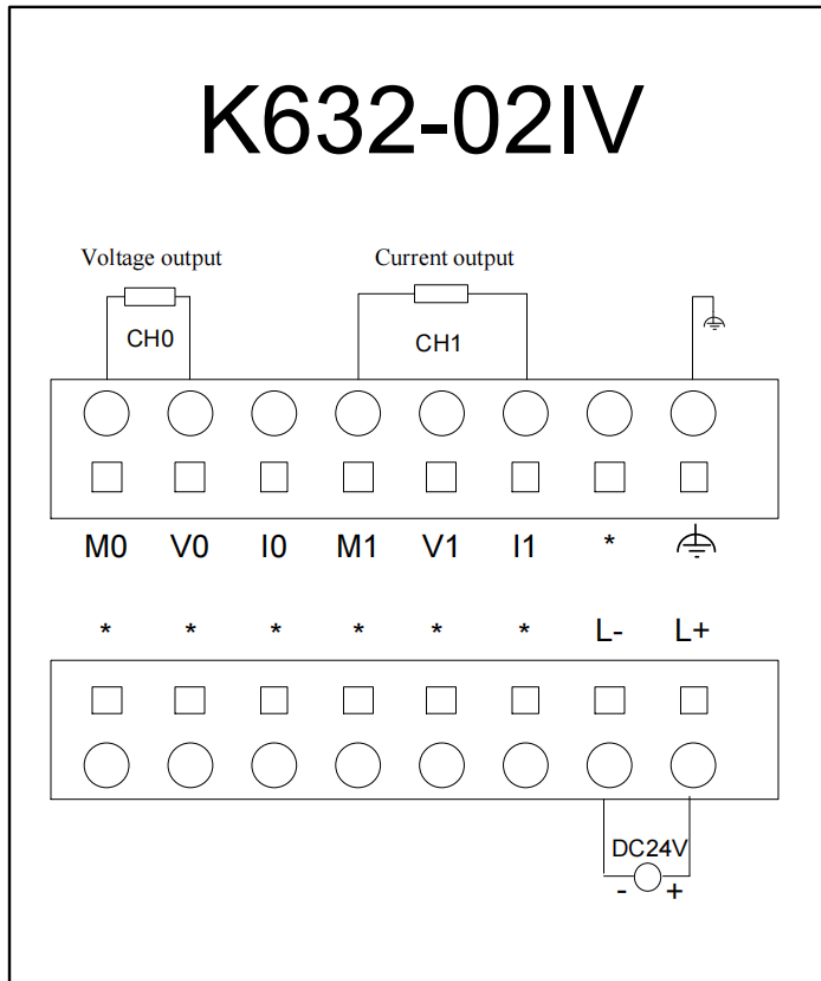

Symbol	Meaning	Symbol	Meaning
L+	Power supply(DC 24V+)	L-	Power supply(DC 24V-)
M0	Channel0: output common terminal	M1	Channel1: output common terminal
V0	Channel0: voltage output	V1	Channel1: voltage output
I0	Channel0: current output	I1	Channel1: current output
*	Unconnected	⏏	Ground

2.3.16 K633-04IV

K633-04IV module is a hybrid module with 2 analog inputs and 2 analog outputs, all of them support voltage or current signals (4~20mA, 1~5V, 0~20mA, 0~10V).

- **Power Supply**

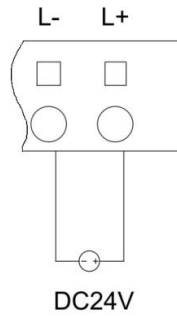

Symbol	Meaning
24V	Power Supply(24V DC+)
0V	Power Supply(24V DC-)

In addition to being powered by the expansion bus, the K633-04IV module also requires an additional connection to DC24V to drive external circuits.

- **AO**

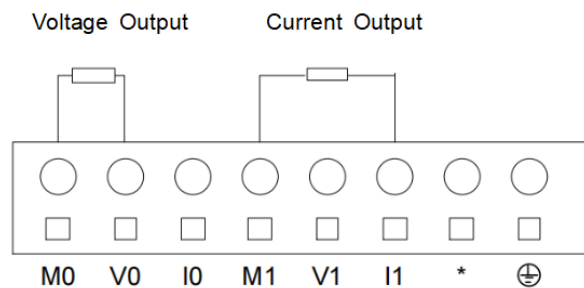

The K633-04IV module provides two analog output channels, supporting current and voltage outputs. The I, V, and M symbols correspond to the current output, voltage output, and common terminal respectively.

For voltage output, connect voltage output "V0" and common "M0" (refer to the wiring example shown on the left side of the diagram above); for current output, connect current output "I1" and common "M0"; for current output, connect current output "I1" and common "M0". If current output is required, connect current output "I1" and common terminal "M1" (refer to the wiring example shown on the right side of the diagram above).

● AI

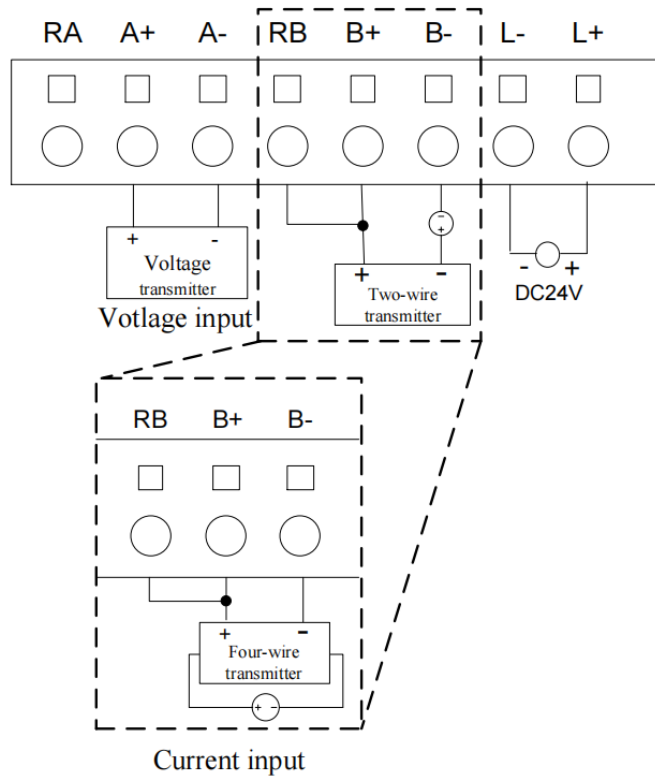

The K633-04IV module provides 2 channels of analog input, supporting both current and voltage signal. For current input, support to be connected with both two-wire or four-wire transmitters. Please refer to the specific wiring method corresponding to the diagram above.

● Wiring Diagram

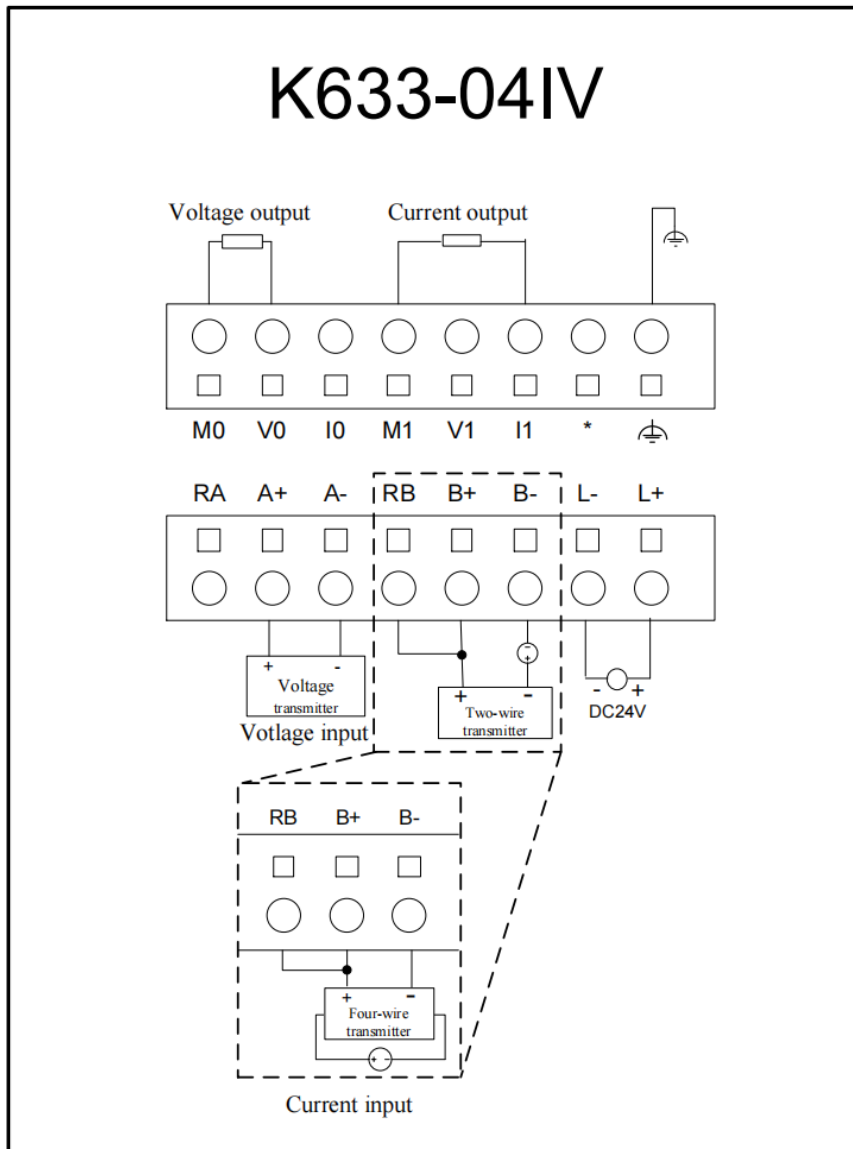

Symbol	Meaning	Symbol	Meaning
M0	Channel0: output common terminal	M1	Channel1: output common terminal
V0	Channel0: voltage output	V1	Channel1: voltage output
I0	Channel0: current output	I1	Channel1: current output
*	Unconnected	⏏	Ground
RA	ChannelA: sampling resistor	RB	ChannelB: sampling resistor
A+	ChannelA: input signal(+)	B+	ChannelB: input signal(+)
A-	ChannelA: input signal(-)	B-	ChannelB: input signal(-)
L+	Power supply:DC 24V(+)	L-	Power supply:DC 24V(-)

2.3.17 K680

The K6 series expansion power supply module is referred to as PS680, and the specific model number is: Kinco-K680. This module's function is to provide +5V operating power and +24V drive power to the expansion modules via the expansion bus. When designing a PLC system, users should ensure that the expansion power capacity provided by the CPU can meet the total power consumption of the target system. If not, the system will not work properly (also trigger the CPU's power output overload protection). In such cases, users can choose another CPU with a stronger power supply capability or add a PS680 at an appropriate position in the system to provide power for subsequent expansion modules.

When more than 7 expansion modules are connected to the CPU, it is recommended to use the PS680 module to enhance the system's expansion capability.

In the expansion bus, expansion modules located before the PS680 will be powered directly by the CPU, and expansion modules located after the PS680 will be powered by the PS680. Therefore, in a system, the customer can decide the position of the PS680 in the expansion bus according to the current loss of the expansion bus and the order of the expansion modules.

The PS680 does not occupy the CPU's I/O image area address and does not require configuration in KincoBuilder; it is plug-and-play. In the same system, please make sure that the AC220V power supply of all PS680s is the same as the AC220V power supply of the CPU.

- Wiring Diagram

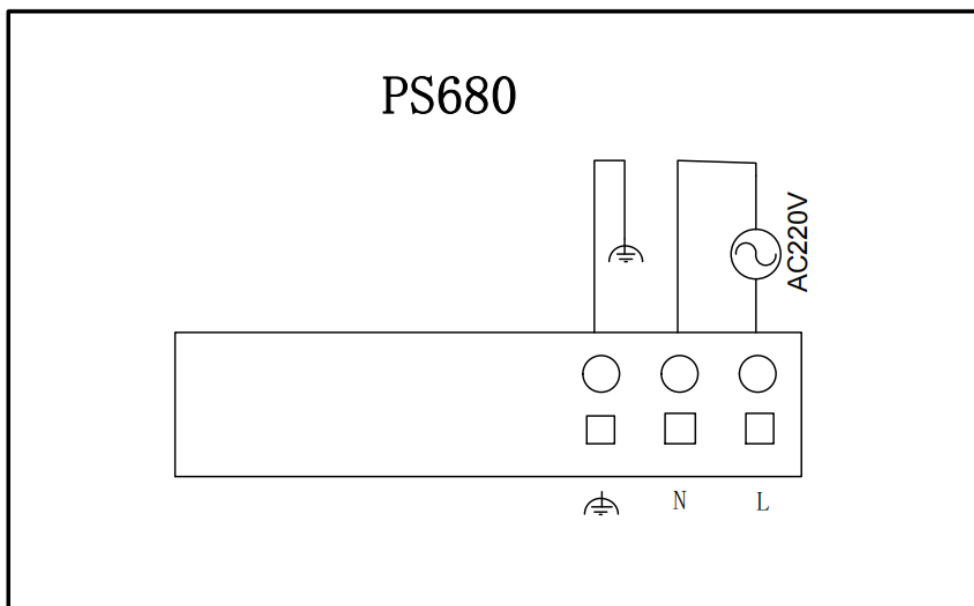

4 Dimension

4.1 CPU Unit

4.1.1 CPU K606

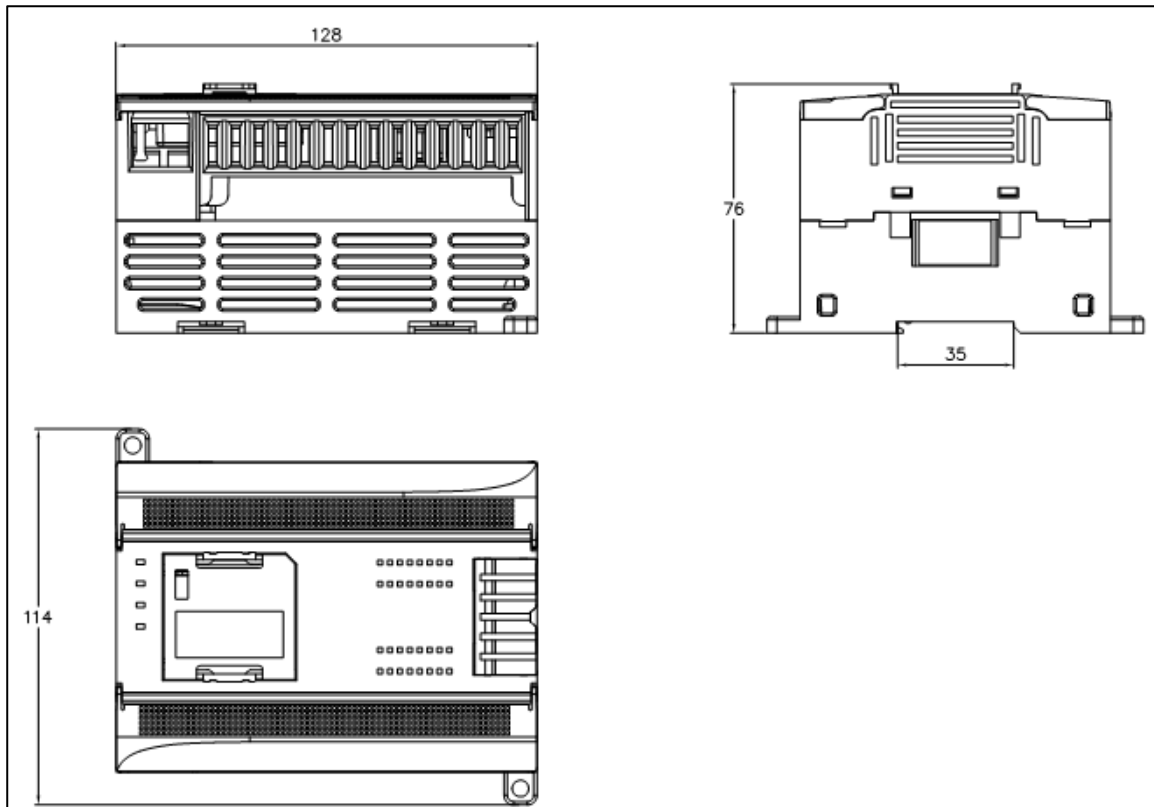

*Unit: mm

4.1.2 CPU K606EA/K608

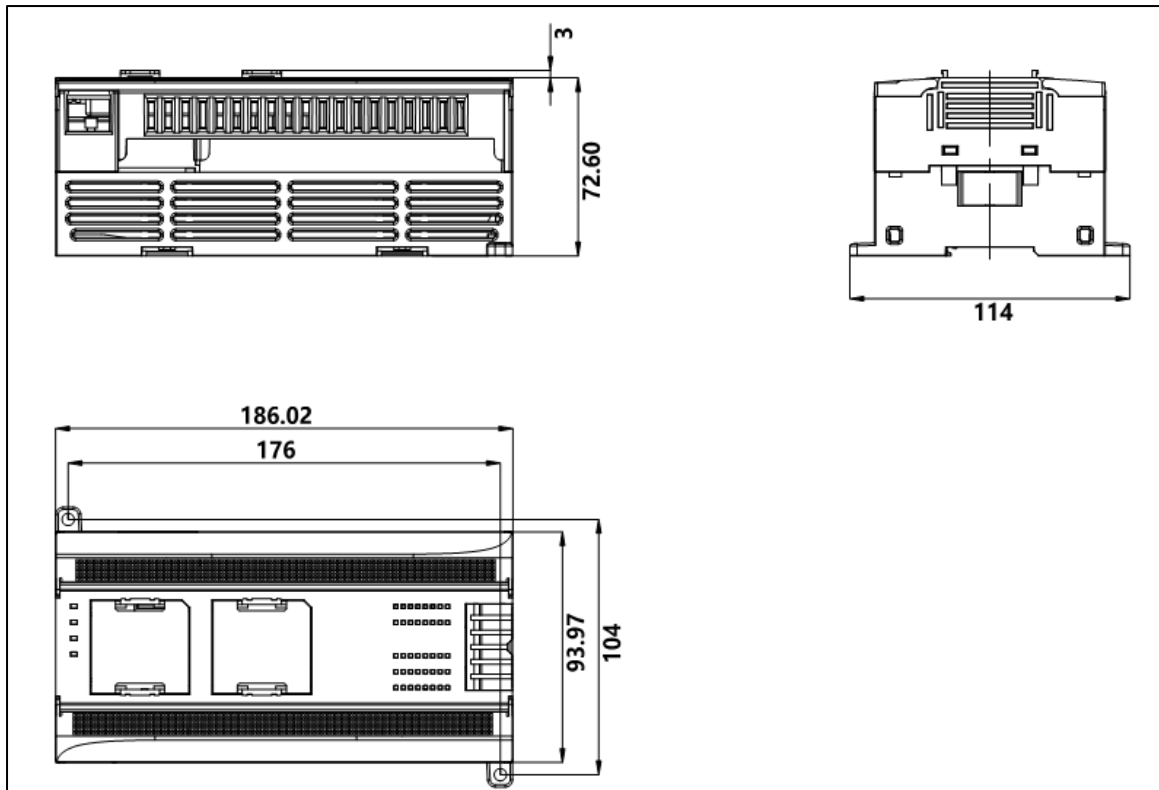

*Unit: mm

4.2 Expansion Modules

4.2.1 K621-08DX/K621-16DX/K622-08DT/K622-08XR/K622-16DT/K622-16XR/K623-08DT/K623-08DR/K623-16DT/K623-16DR/K680

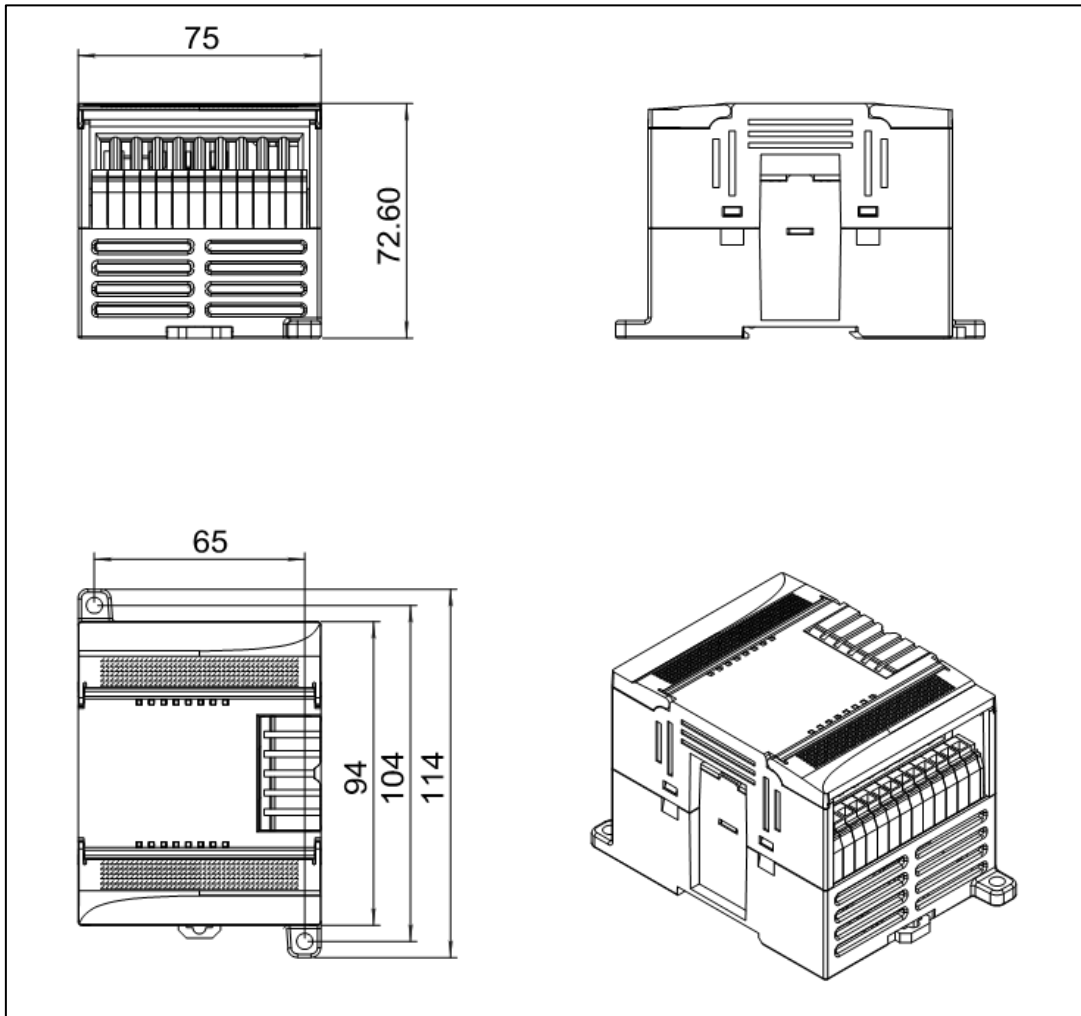

*Unit: mm

4.2.2 K631-04IV/K631-04TC/K631-04RD/K632-02IV/K633-04IV

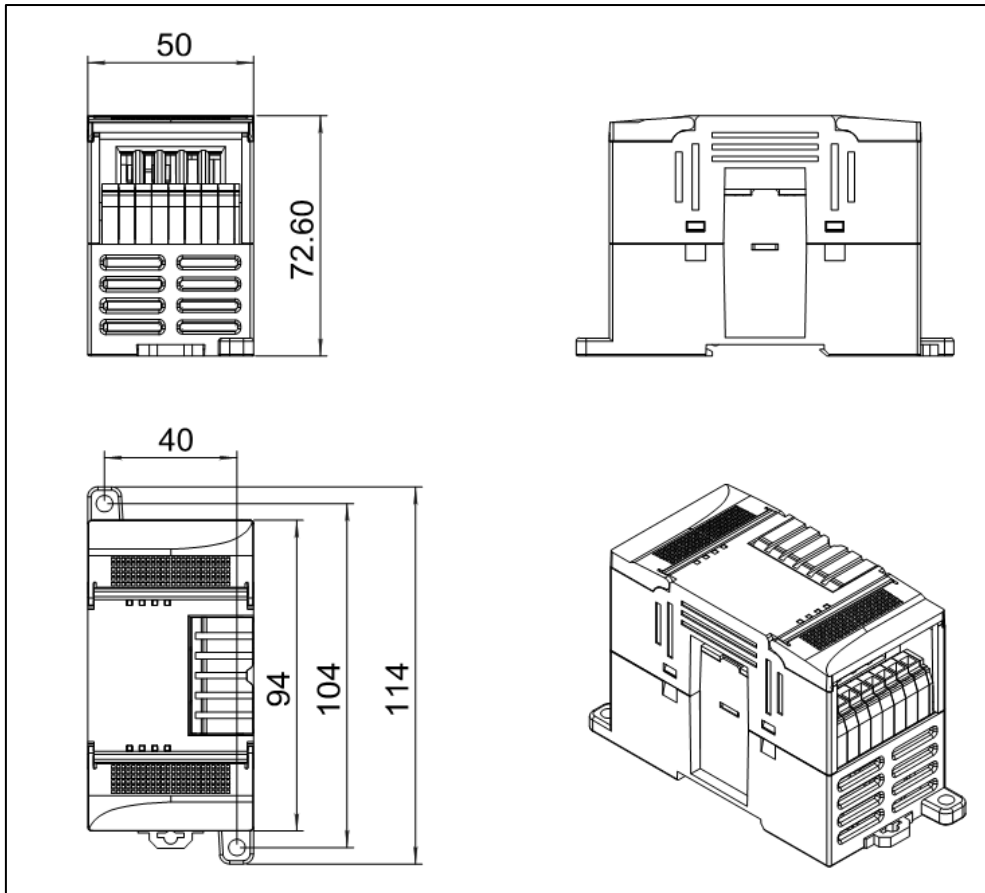

*Unit: mm

5 Assembly Guidelines

5.1 Connection of CPU and Modules

The K6 series products are connected with a special flat flexible cable.

In actual connections, the CPU module is always arranged on the far left. The expansion bus cable is led out from the CPU's expansion interface and connected to the expansion modules successively from left to right. When connecting, the expansion bus output interface of the left module should be connected to the expansion bus input interface of the right module. After connecting all the expansion modules, please ensure that all the modules are pushed tightly together, allowing the expansion cables to naturally slide into the cable shielding groove on the left side of the modules.



If the CPU is connected to a large number of expansion modules or if the distance of the expansion bus exceeds 0.5 meters, it is recommended to use a short jumper wire to short-circuit pins 9 and 10 in the expansion interface of the last module to enhance system stability.



⚠ Notes:

1. Please ensure that the expansion cables are securely connected to avoid communication failures due to poor contact.
2. After assembly, please push all modules tightly together, allowing the expansion cables to naturally slide into the cable shielding groove, and tighten all the expansion cover plates to protect the expansion cables.
3. When a large number of expansion modules are connected to the CPU, it is recommended to use a short jumper wire to short-circuit pins 9 and 10 in the expansion interface of the last module. It will enable internal resistance, enhancing the stability of the expansion bus

communication.

5.2 Assembly of BD Expansion Module

The CPU module provides 1-2 BD expansion slots (CPU K606 supports 1 slot, CPU K606EA and CPU K608 support 2 slots), with each slot having a unique position number. From left to right, they are labeled as BD0 and BD1, as shown in the diagram below.

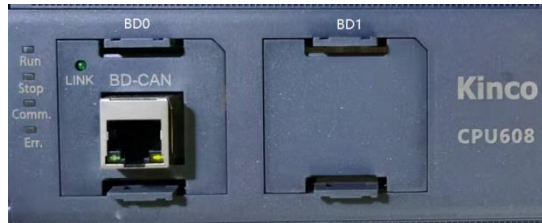

⚠ Notes:

1. Communication-type BD expansion modules can be applied only in BD0; there is no such restriction for IO-type BD modules.
2. Before assembly or removing BD expansion modules, make sure the CPU is powered off. Otherwise, there is a risk of damaging the equipment.

5.3 Dis/Assembly of Terminal Blocks

5.3.1 Disassembly of the Terminal Blocks

① Open the terminal cover.

- Insert the screwdriver vertically into the notch at the center of the terminal block.
- Pry the terminal block outward (downward).

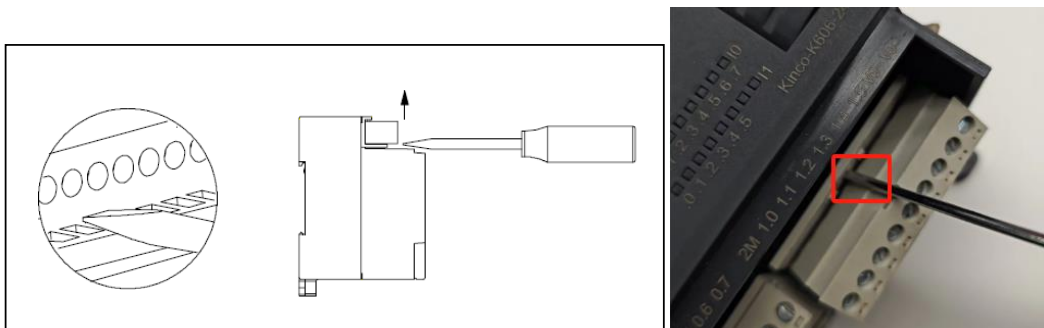

5.3.2 Assembly of Terminal Blocks

① Open the terminal cover.

- Place the protrusion at the rear of the terminal block into the locating hole on the terminal

slot.



- Ensure that the pins on the module are aligned with the holes at the edge of the terminal block, then press down forcefully until the terminal block is flush with the terminal slot.



5.4 Mounting Guidelines

5.4.1 Mounting with DIN Rail

5.4.1.1 Standards of Din Rail

DIN rail mounting is a common industrial mounting method that allows the device to snap directly onto the rail without the need for screws. The standard width of DIN rails is 35 mm, and the following two specifications are commonly used.

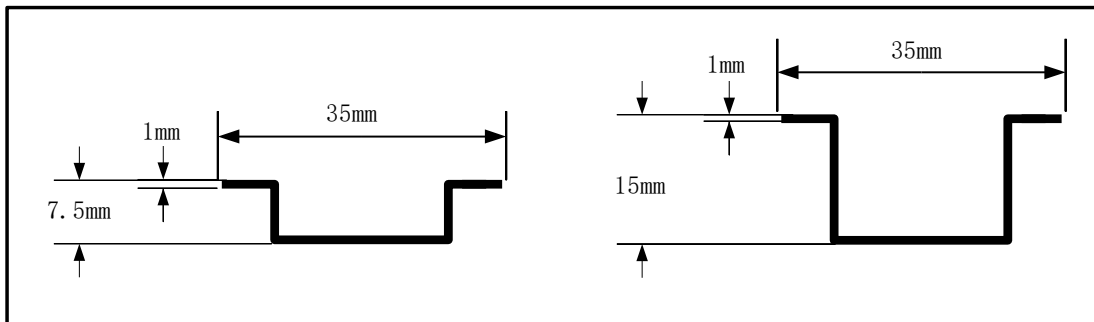

5.4.1.2 Mounting/Dismounting

Mounting:

1. Secure the DIN rail first. For horizontal mounting, make sure that there is at least 60mm of space below the rail on both sides; for vertical mounting, make sure that there is at least 60mm of space on each side of the DIN rail.

2. Pull the module's rail slider down (pull down to unlock, push up to lock), Snap the top end of the module's rail connection to the edge of the rail, and press the module down into the rail.

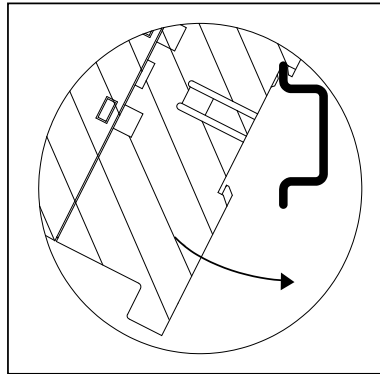

3. Using the above method to mount all modules onto the DIN rail. Then, move the modules to the appropriate positions, connect the expansion interfaces of each module one by one, and finally push the clips of each module tightly to secure them. The mounting result is as shown in the figure below:



Fig.3.4-4 Pull Down to Unlock



Fig.3.4-5 Push Up to Lock

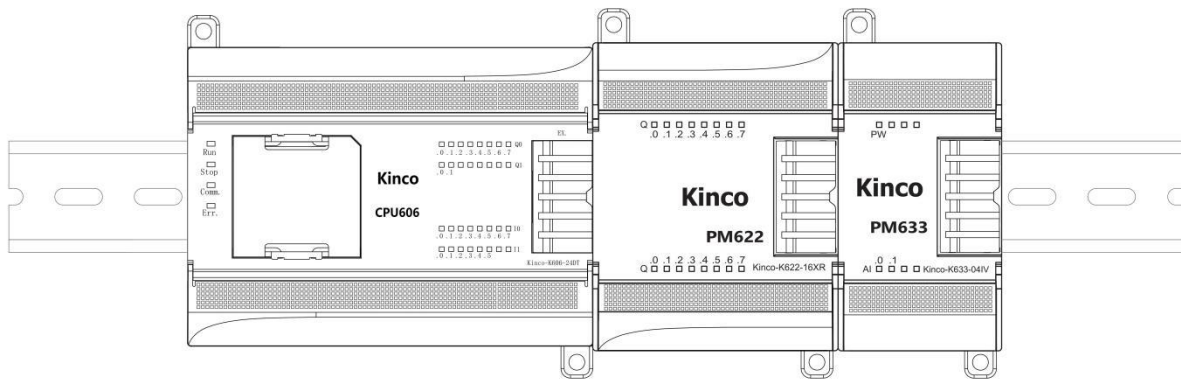

⚠ Notes:

1. To ensure proper ventilation and heat dissipation, please leave at least 60mm of space above and below the modules during mounting. Additionally, ensure a depth of at least 100mm.
2. When vertically mounting, the upper limit of the operating environment temperature will decrease by 10° C.
3. For DIN rail mounting, please connect all modules to the rail before expansion connection, otherwise the expansion interface may be damaged.

Dismounting Any of the Modules:

1. Pull down the sliders of all modules' DIN rails to release them from fixation.
2. Remove the plug heads of the expansion cables on both sides of the module that needs to be disassembled.
3. With the module to be disassembled at the center, push the other modules aside on both sides to facilitate the removal of the targeted module.
4. Pull the targeted module upward from the bottom of the DIN rail.

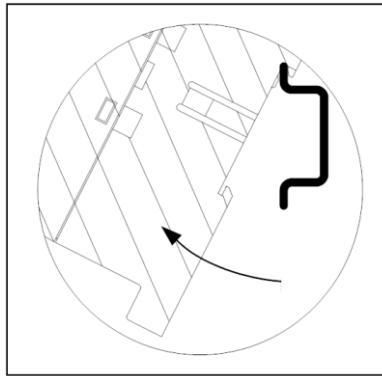

5. After disassembly, reassemble the remaining modules following the installation steps.

5.2.4 Mounting with M4 Screws

K6-series products are equipped with two M4 bolt mounting holes, located in the upper-left and lower-right corners of the enclosure, and the two holes should be secured with M4 bolts for mounting.

Mounting Procedure:

- ① Prepare the mounting board and punch holes according to the system's electrical layout diagram. Please refer to the following guidelines for designing the dimensions of the mounting board's locating holes: for horizontal mounting, the CPU module should be located on the leftmost side; for vertical mounting, the CPU module should be located at the top.

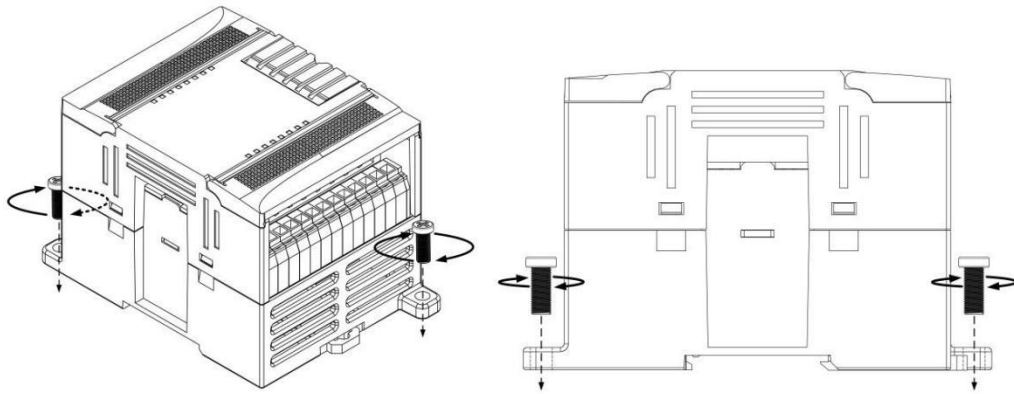

②Fasten the modules to the mounting plate with bolts in sequence, then connect the expansion buses of each module in turn, and finally let the expansion cables slide naturally into the shielded wire slots on the left side of the module to protect the cables.

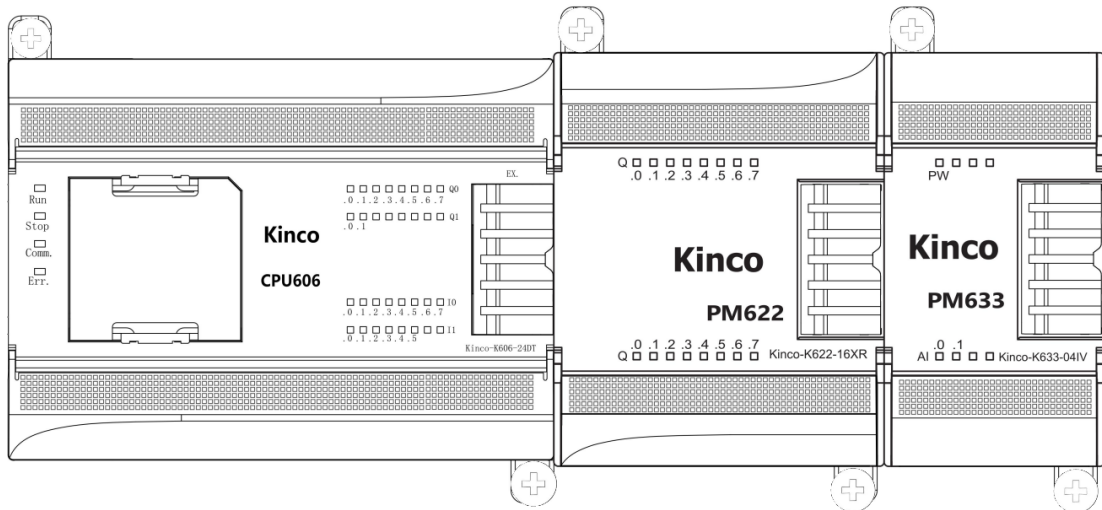

*To prevent loosening of the equipment due to prolonged external vibration, it is recommended that spring washers and shims be added to the fastening bolts to ensure effective fastening.

6 Getting Started

KincoBuilder is a programming software for Kinco's K-series PLCs, compliant with the IEC 61131-3 standard, enabling users to carry out efficient program development. Here is a brief getting started guide to assist users in quickly getting acquainted with KincoBuilder.

6.1 Introduce of Interface

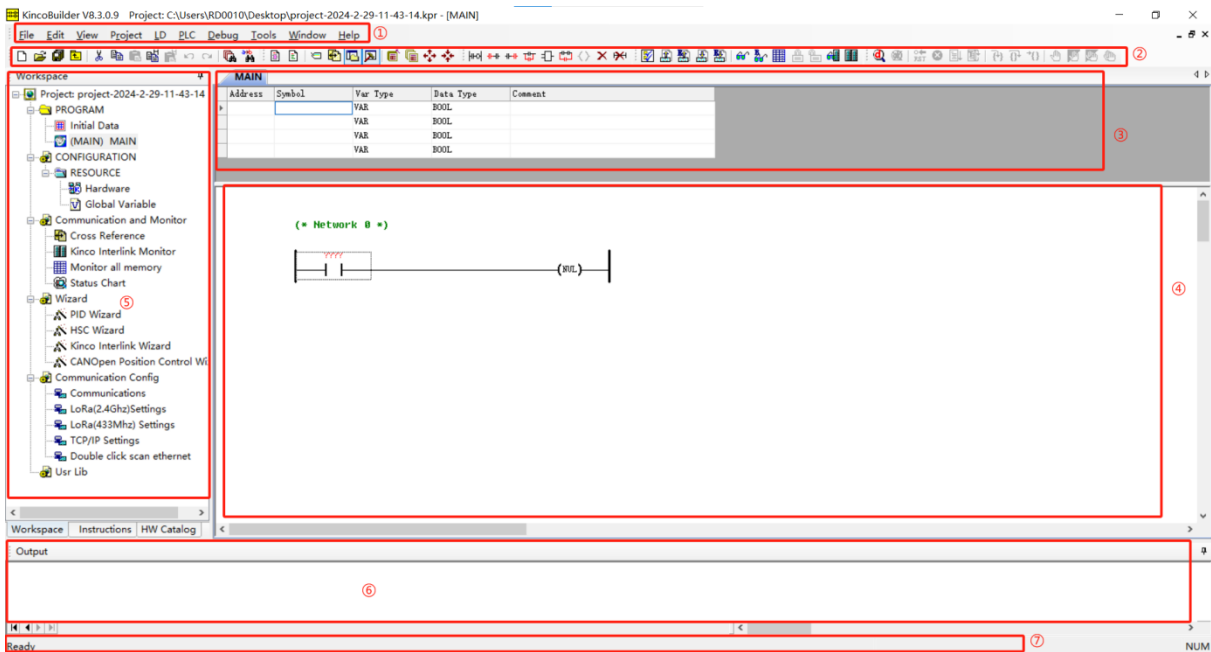

No.	Item	Description
①	Menu bar	The Project menu contains all the operational commands of the KincoBuilder.
②	Toolbar	The Toolbar contains some frequently used operational commands.
③	Variable Definition Area	For variables declaration.
④	Programming Area	For program editing ,the LD editor or IL editor can be chosen optical.
⑤	Project Management Area	The Project Manager is one of the main windows in the interface, which intuitively links all components of the current project in a tree structure, including programs, hardware(configurations), status chart, global variable(tables), etc. Users can manage, operate, and maintain the current open project in this device tree. Each node in the project manager supports right-click operations to pop up corresponding windows.
⑥	Output	Information window, is used to display various prompts of the KincoBuilder. The

		"Compile" window shows the compilation information of the user's last compilation.
⑦	Status Display Bar	The status bar is used to display the current status of the software and prompts for operational commands.

KincoBuilder has organized some commonly used functions into sections on the toolbar for user convenience. Hovering the mouse pointer over the corresponding icons allows to view brief descriptions of the functions and their corresponding shortcut key operations. For more detailed information, please refer to the relevant application manual.

6.2 Create a New Project

There are two ways to create a new project in KincoBuilder. Firstly, open the software by double-clicking the KincoBuilder icon . The following image shows the initial interface after opening the software:

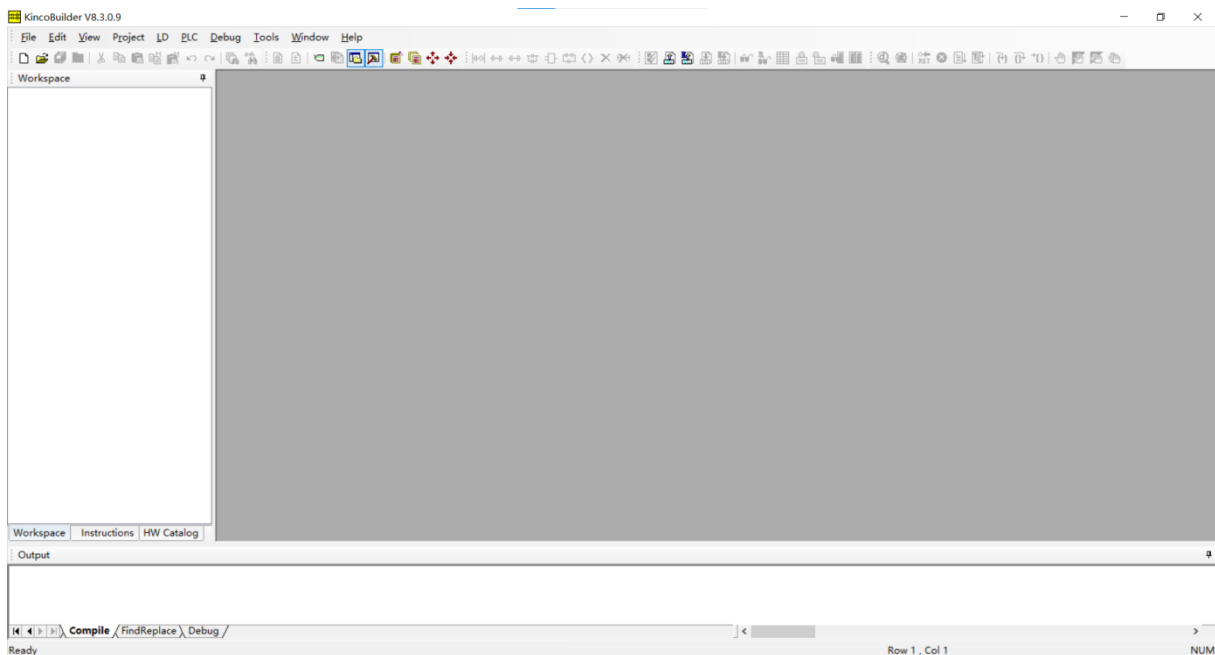

Users can create a new project by selecting [New Project...] under the [File] menu in the menu bar. Alternatively, you can quickly create a new project by clicking the [Create a new project] on the toolbar.

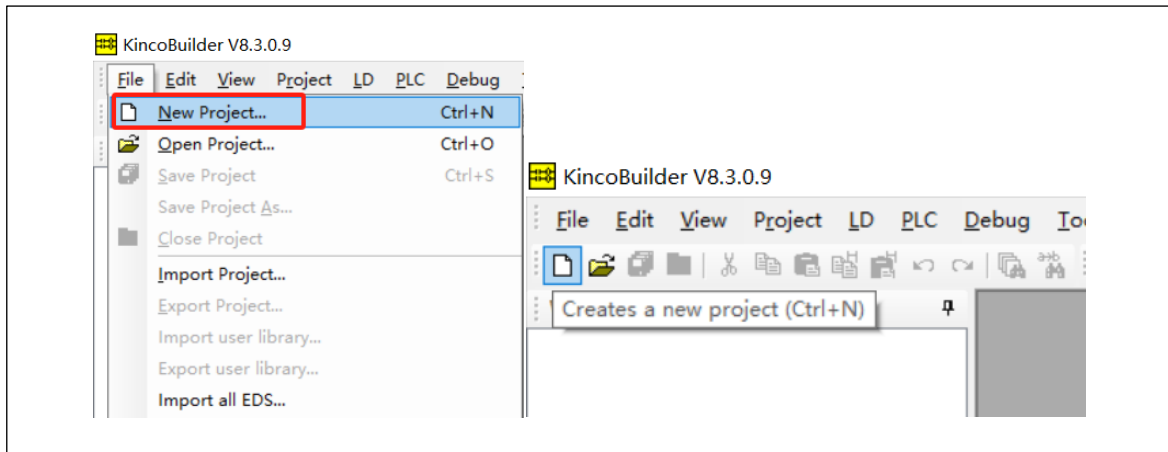

In the pop-up [New Project...] dialog box, select the location to save the project, modify the project name and then click "Save" to complete the creation.

6.3 Hardware Configuration

6.3.1 Configure the CPU

After creating a new project, the program will default to configuring the CPU as K606-24DT (The model here is not fixed and may vary depending on the software version, and it can be changed by opening [Option] from [Tools]). Users should modify it according to the actual hardware model.

Here's an example for how to configure the CPU. Find [Hardware] in the device tree and double-click to open the hardware configuration interface.

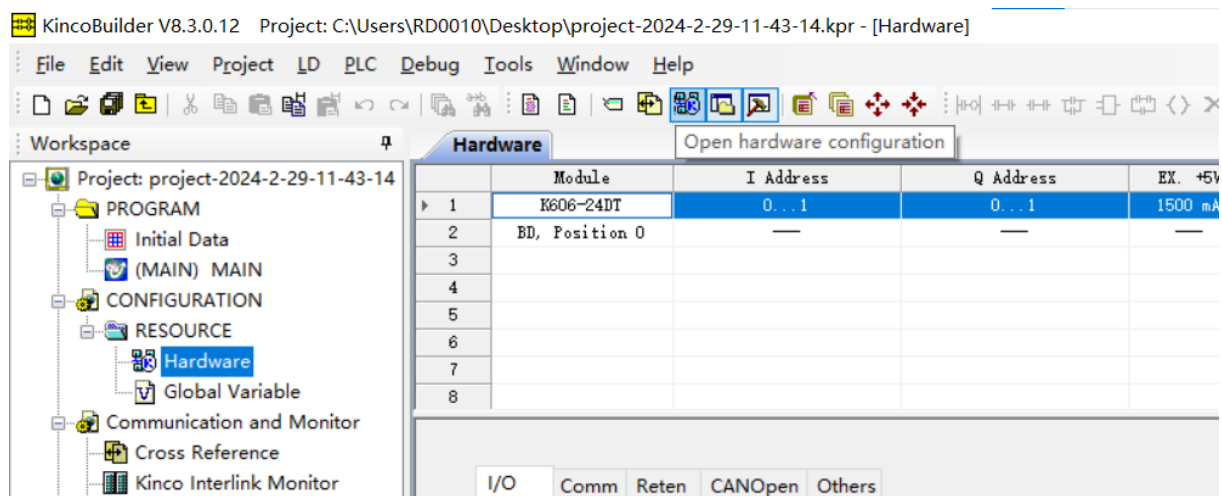

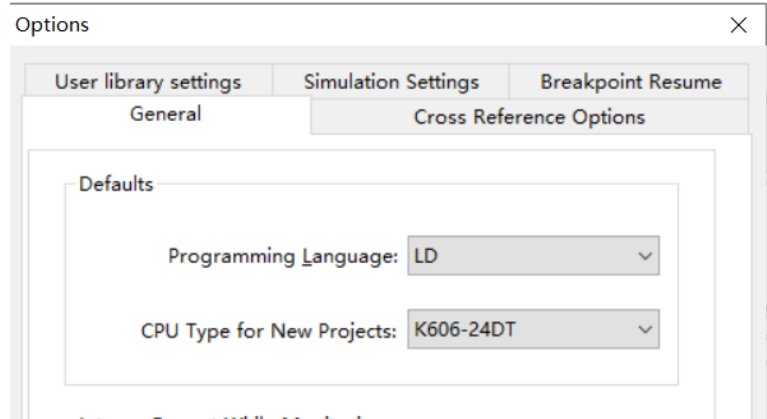

After opening the [Hardware] interface, the first row displayed in the hardware configuration list is indeed the currently configured CPU. When changing the configuration, you need to delete the module configured (Right-clicking on the module name to delete the configured module). Then, in the [HW Catalog], find the module that needs to be configured, and double-click to automatically add it to the project.

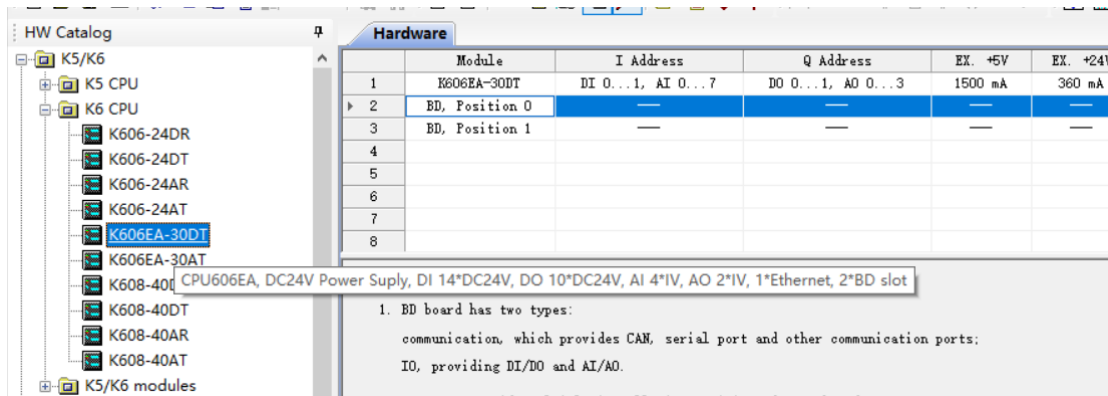
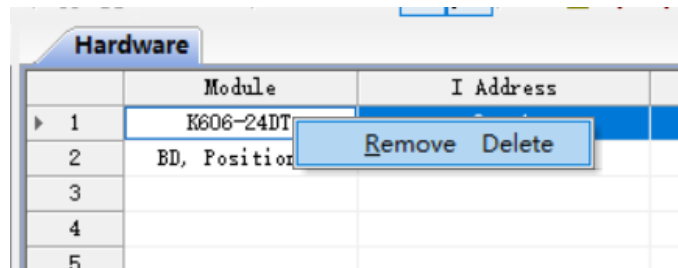

Check the configured model to configure I/O, communications, data retention, CANopen master, etc.

Hardware

	Module	I Address	Q Address	EX. +5V	EX
1	K606EA-30DT	DI 0...1, AI 0...7	DO 0...1, AO 0...3	1500 mA	3
2	BD, Position 0	---	---	---	
3	BD, Position 1	---	---	---	
4					
5					
6					
7					
8					

I/O Comm Reten Local AI Local AO CANOpen Others

I Address

Start: Length: bytes

Input Filters(ms)

10.0-0.3	<input type="text" value="0.0"/>	10.4-0.7	<input type="text" value="0.0"/>
11.0-1.3	<input type="text" value="0.0"/>	11.4-1.7	<input type="text" value="0.0"/>
12.0-2.3	<input type="text" value="0.0"/>	12.4-2.7	<input type="text" value="0.0"/>

Q Address

Start: Length: bytes

Output States while Stop

Select All

0 1 2 3 4 5 6 7

Q0.x

Q1.x

6.3.2 Configure the Expansion Modules

The first column in the [Hardware] configuration items represents the configured CPU module. KincoBuilder will automatically configure the number of slots for BD expansion modules that match the configured CPU. You can select blank rows other than this and double-click on the expected module in [HW Catalog](Hardware Catalog) to configure the expansion modules. In KincoBuilder, the order of modules configured in [Hardware] must strictly match the physical module connection order, or else it will cause errors in the CPU.

Similar to the CPU configuration, clicking on the corresponding module in [Hardware] allows configuration of it.

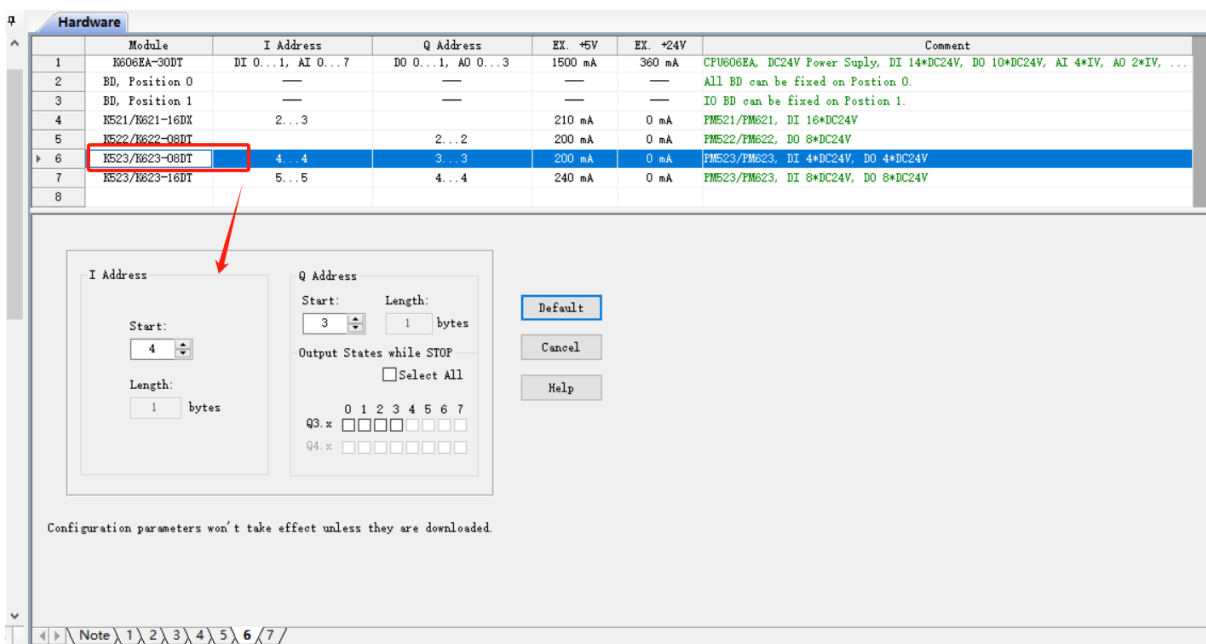
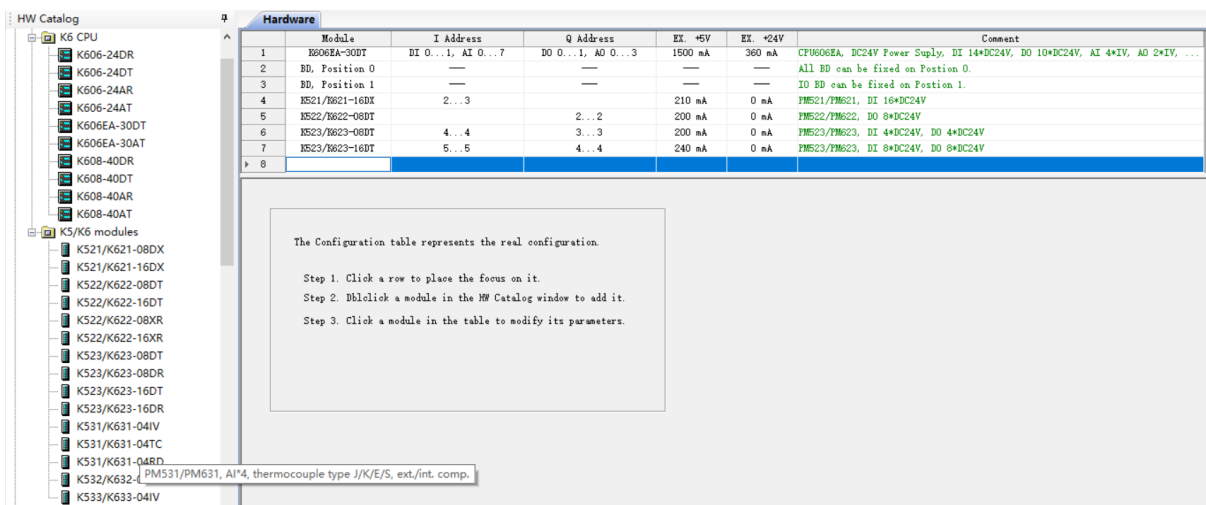

⚠ Note: In KincoBuilder, the configuration order of expansion modules must match the actual hardware connection sequence. Otherwise, it may cause errors in the PLC.

6.3.3 Configure the BD Modules

The first column in the [Hardware] configuration items represents the configured CPU module. KincoBuilder will automatically configure the number of slots for BD expansion modules that match the configured CPU. You can double-click on the expected BD module in [HW Catalog] to configure the BD expansion module after selecting the corresponding BD channel(row).

Selecting the blank row of BD expansion slot (unconfigured) will display the BD configuration instructions for specified channel. Selecting the BD expansion row that configured will allow you to configure the module.

Module	I Address	Q Address	EX. +5V	EX. +24V	Comment
K606EA-30DT	DI 0...1, AI 0...7	DO 0...1, AO 0...3	1500 mA	360 mA	CPU606EA, DC24V Power Supply, DI 14*DC24V, DO 10*DC24V, AI 4*IV, AO 2*IV, ...
BD, Position 0	---	---	---	---	All BD can be fixed on Postion 0.
BD, Position 1	---	---	---	---	IO BD can be fixed on Postion 1.
K521/K621-16DX	2...3		210 mA	0 mA	FM521/FM621, DI 16*DC24V
K522/K622-08DT		2...2	200 mA	0 mA	FM522/FM622, DO 8*DC24V
K523/K623-08DT	4...4	3...3	200 mA	0 mA	FM523/FM623, DI 4*DC24V, DO 4*DC24V
K523/K623-16DT	5...5	4...4	240 mA	0 mA	FM523/FM623, DI 8*DC24V, DO 8*DC24V

1. BD board has two types:
communication, which provides CAN, serial port and other communication ports;
IO, providing DI/DO and AI/AO.

2. KPLC can provide multiple installation positions for BD boards,
among which position 0 (the first on the left) supports all types of BD boards.
In other locations, only BD boards of the IO class are supported.

3. It does not matter whether a BD board is inserted in this table.
After powering on and downloading the program,
the CPU module automatically detects whether the BD board and its model exist.
If a BD board is inserted in the table, the model must be the same as the BD board in use.
If a BD board is not inserted in the table but is used in practice,
the CPU automatically processes the BOARD based on the detected BD board model.
Communication BD board will adopt the corresponding function configuration in the user project;
IO class BD board will adopt default parameters.

4. IO class BD board Assign the default DI/DO/AI/AO start address, which can be modified by users.

Similarly, in KincoBuilder, if the BD channel is configured, the order of BD modules configured in [Hardware] must strictly match the physical module connection order, or it will result in CPU errors. If there is a module physically inserted into a specific BD slot but no configuration is set for that channel in the user's project (in KincoBuilder), the CPU will automatically handle it based on the detected BD expansion model.

For communication-type BD expansion modules, the CPU will adopt the parameters and functional configuration of the corresponding communication port in the user's project.

BD Module		Default Configuration
		BDO
KB6-2COM	PORT0	PLC Address(Station): 1
	(RS232)	Baud Rate: 9600bps Parity: None

		Data Bits: 8 Stop Bits: 1
	PORT3 (RS485)	PLC Address(Station): 1 Baud Rate: 9600bps Parity: None Data Bits: 8 Stop Bits: 1 Default to be configured as Modbus RTU slave.
KB6-COM	CAN2	Baud Rate: 500kbps SDO Timeout: 60ms Default delay of 3s for master startup, and when master startup, it will automatic configure slaves. Default PDO configuration is empty.

For IO-type BD expansion modules, the CPU will operate by default configured addresses and signal types. The default starting addresses for IO channels on IO-type BD expansion modules located in different BD slots(BD0/BD1) are as follows:

BD Module	Default Address	
	BD0	BD1
KB6-4DI	IB30	IB31
KB6-4DO	QB30	QB31

The above table shows the default address corresponding to different models of IO-type BD expansion modules in different BD slots. For example, if there installs a KB6-4DO module in the BD0 slot, the addresses corresponding to the expansion DO channels are Q30.0, Q30.1, Q30.2, and Q30.3 respectively.

6.4 Programming Simplified Guide

6.4.1 On-line Help

In KincoBuilder software built-in more detailed instructions, the user can click on the toolbar [Help] → [Contents and Index] to open the online-help interface to find programming instructions quickly.

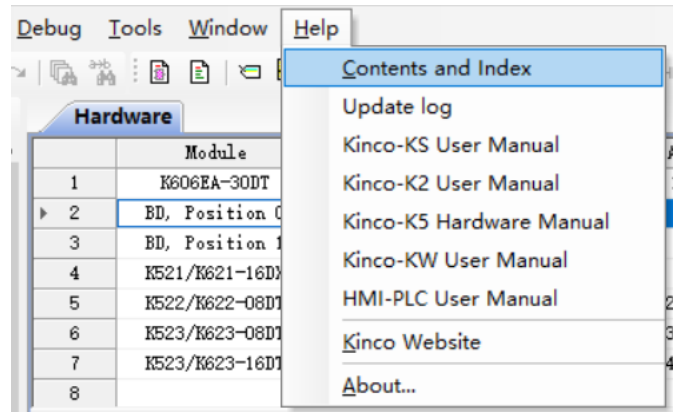

In the left navigation bar, it supports finding detailed instructions through browsing the directory, keyword indexing, and searching. It also supports adding the found information to the favorites folder.

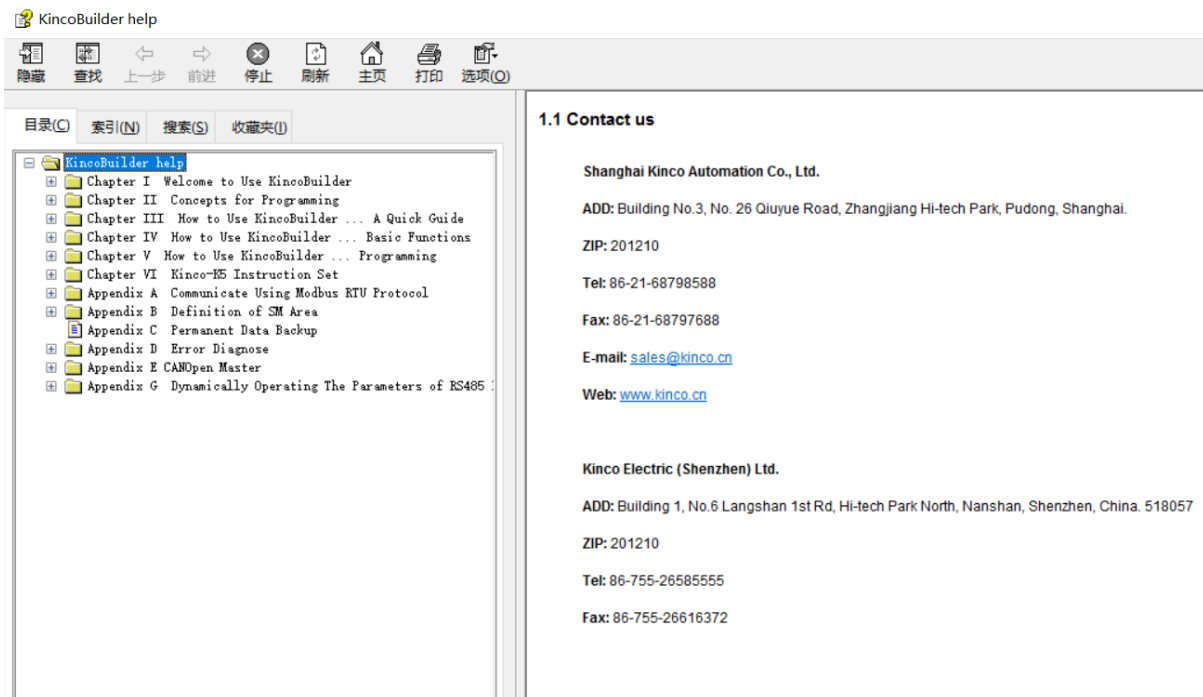

6.4.2 Programming Languages

KincoBuilder supports programming using IL (Instruction List) language or LD (Ladder Diagram) language. You can switch between these languages in the software by accessing the toolbar and selecting [Project].

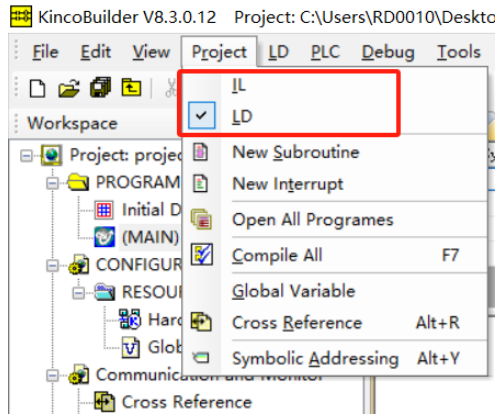

6.4.3 Programming Instructions

This section does not introduce the specific usage of programming instructions. It only explains how to quickly obtain help and instructions for programming instructions:

1. After selecting a specific instruction in the edited program, press the F1 shortcut key, then will automatically open the online help and navigate to the corresponding instruction's explanation.

The screenshot shows the KincoBuilder help window. The main window displays a ladder diagram with an 'ADD' instruction highlighted in red. A red arrow labeled 'f1' points from the instruction to the help window. The help window shows the '6.8.1 ADD and SUB' section, which includes a table with the following data:

LD	Name	Usage	Group
	ADD	EN ADD ENO IN1 IN2 OUT	
IL	ADD	ADD IN1, OUT	U
	SUB	SUB IN1, OUT	

Below the table is another table with the following data:

Operands	Input/Output	Data Type	Acceptable Memory Areas
IN1	Input	INT, DINT, REAL	I, Q, AI, AQ, M, V, L, SM, T, C, HC, constant, Pointer
IN2	Input	INT, DINT, REAL	I, Q, AI, AQ, M, V, L, SM, T, C, HC, constant, Pointer
OUT	Output	INT, DINT, REAL	Q, AQ, M, V, L, SM, Pointer

Below the tables are sections for 'LD' and 'IL' instructions, providing additional details about their usage and data types.

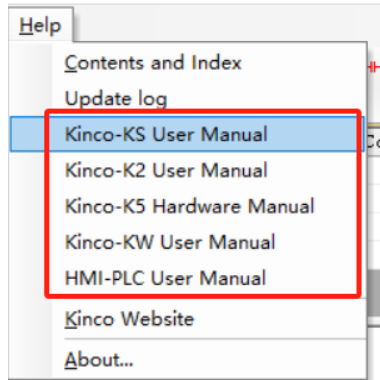

2.To find the usage of the corresponding instructions through the software manual. Please download the software user manual from the official Steps website. Product version iterations may lead to some lag in both the software and its user manual. Please ensure to download the latest version of the software and the corresponding user manual from the official website promptly. (<https://www.kinco.cn/download/plc25.html>)

6.5 Compiler and Simulator

6.5.1 Compiler

The PLC compiler will verify all instructions supported by the actual PLC and the structure of user programs. All errors in the KincoBuilder compiler will be listed in the [Output] window. Double-clicking on error messages listed in the [Output] window will automatically locate the error.

The program can be compiled by clicking [Project] → [Compile All] on the toolbar, or by using the [F7] shortcut key. After successful compilation, the number of generated instructions will be displayed.

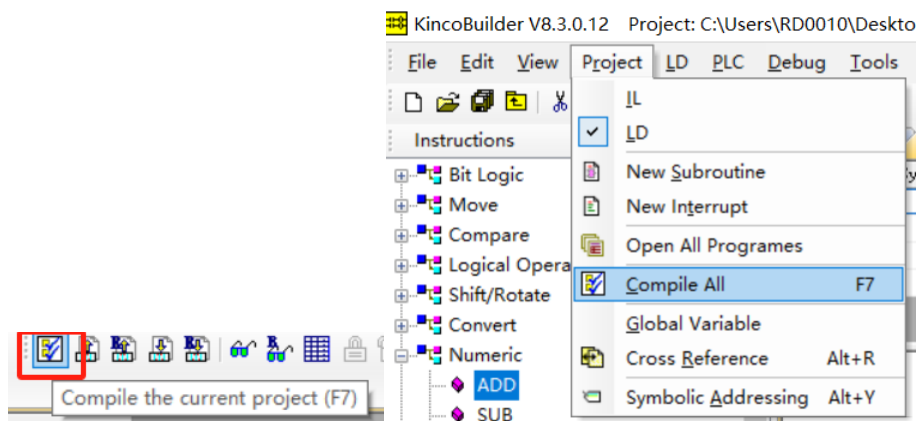

6.5.2 Simulator



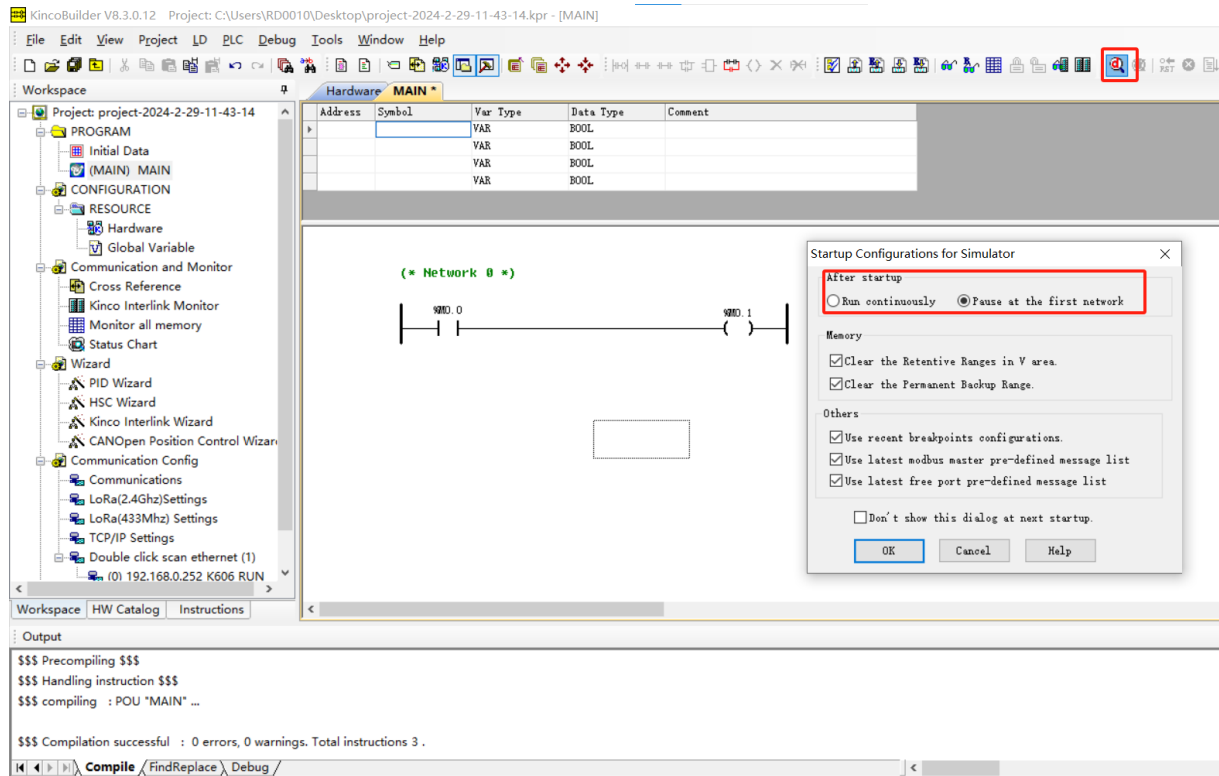





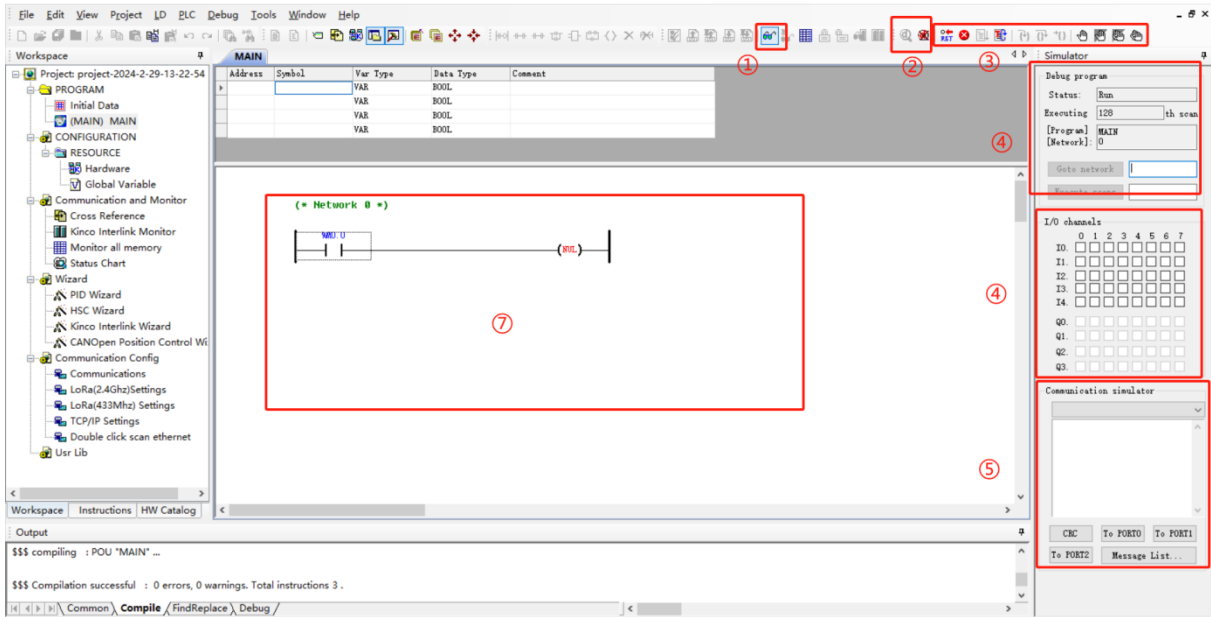





In KincoBuilder, an offline simulator for KPLC is provided, supporting simulation of actual program execution and debugging of user programs while offline. The simulator offers practical debugging features such as breakpoints, single-step execution, single-network execution, pause/resume operation, and serial communication simulation.



Option	Description
Run continuously	After the simulator is started, it performs cyclic scanning and execution of the program.
Pause at the first network	After the simulator is started, it stops executing after completing the first scan cycle.

*For more detailed instructions on using the software, please refer to the KincoBuilder Programming Manual.



No	Item	Icon/Description
①	Toggles Monitoring Mode	 : Click to enter or exit monitoring mode.
②	Enter/Exit Simulation Mode	 : Click to enter offline simulation mode.  : Click to exit offline simulation mode.
③	Function Shortcuts for Offline Debugging	 : Restart the simulation.  : Stop the program execution.  : Continual the program execution.  : adjust the scan cycle of simulation.  : Execute an instruction.  : Execute a network.  : Execute to the network where cursor(line).  : Add/remove the breakpoint.  : Disable/enable the breakpoint.  : Disable all breakpoints.  : Enable all breakpoints.

④	Debug Program	<p>The [Debug program] window includes features such as:</p> <ul style="list-style-type: none"> • Current status display • Execution of scan cycles(executed) • Program network display(current) • Jump to the next network • Execute the specified scan cycles
⑤	I/O channels	<p>Input or output signals can be simulated by checking the corresponding IO channel option.</p>
⑥	Communication Simulator	<p>Suitable for simple communication simulation debugging of XMT RCV commands.</p>
⑦	Programming Area	<p>This area allows the user to observe the program running and debug the program manually.</p>

*For more detailed instructions on using the software, please refer to the KincoBuilder Programming Manual.

6.6 PLC Connection and Program Up/Download

6.6.1 Communication between PC and K6-series PLC

- **Communicate Via Ethernet Interface:**

1. Connect the PLC and PC correctly with a standard network cable, and power on the PLC;
2. Select [Tools] in the toolbar → [Communications] → [Scan Net], or directly double-click on [Double click scan Ethernet] in the device tree to scan the device. KincoBuilder also supports modifying the IP address of the scanned PLC across different network segments. Since the K6 series PLC and KincoBuilder only can communicate in the same LAN segment, it is necessary to modify the IP address of the target PLC or the PC's IP address to ensure they are on the same LAN segment before any operation.

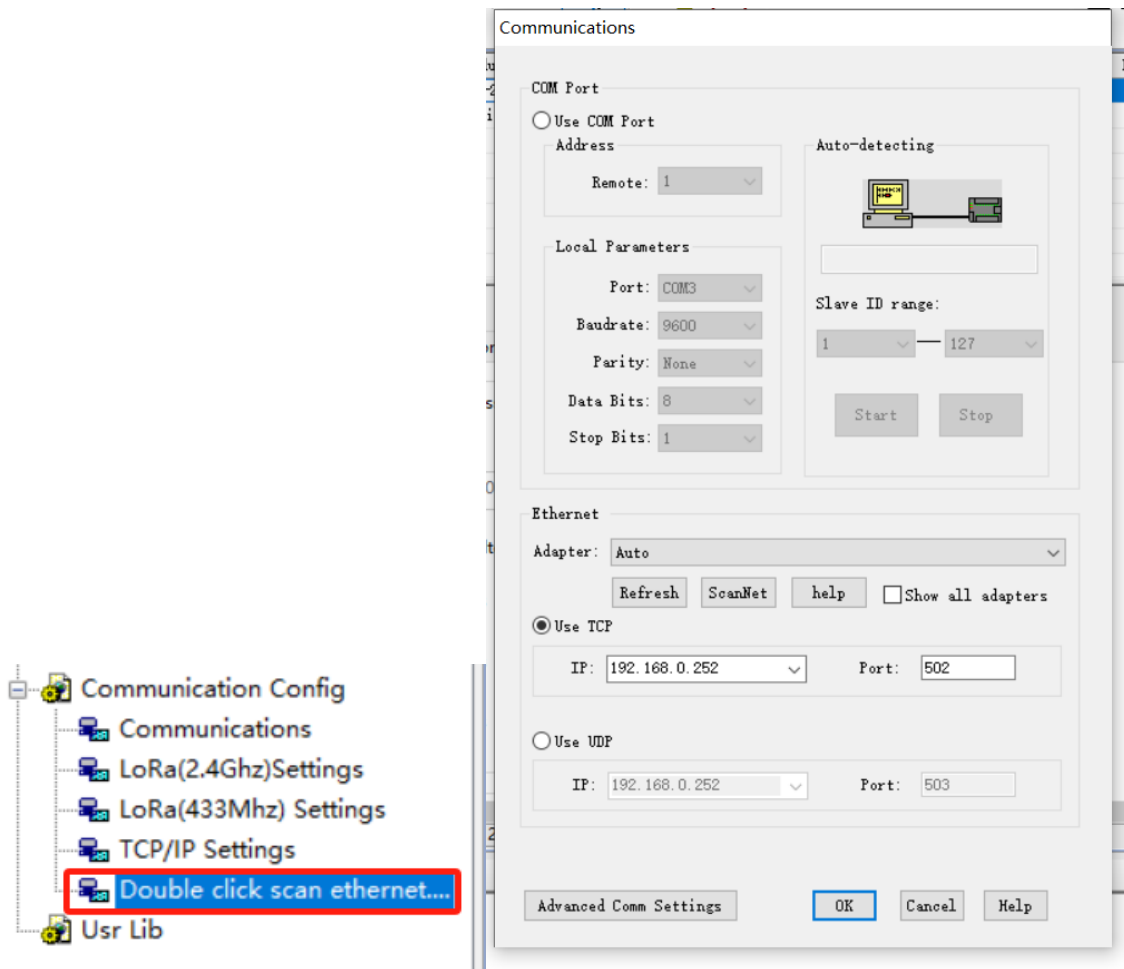

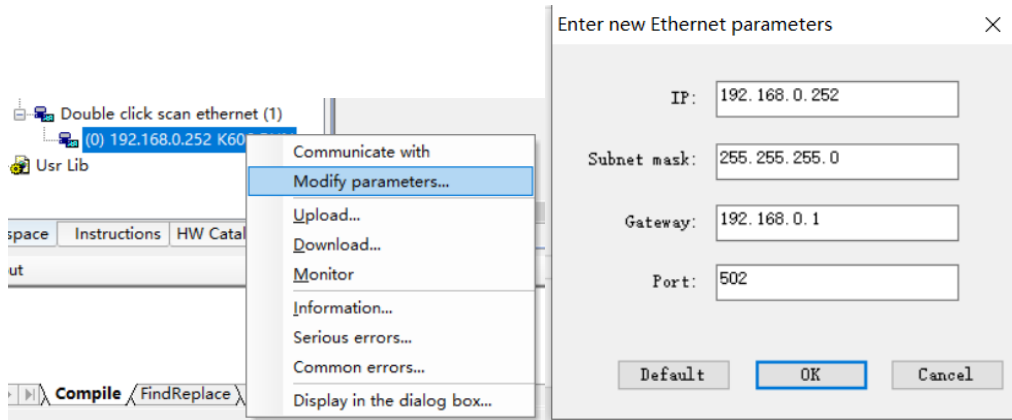

If you need to modify the IP address of the PC, please follow these steps in the PC system settings:

- ① Open the Control Panel or search for "Control Panel" in the Start menu to open it.
- ② In the Control Panel, select the "Network and Internet" option.
- ③ In the "Network and Internet" window, select the "Change adapter settings" link under "View network status and tasks".
- ④ In the "Network Connections" window, locate the network adapter you are currently using (usually Ethernet adapter or Wi-Fi adapter), right-click on it, and select "Properties".
- ⑤ In the pop-up properties window, find and double-click on the "Internet Protocol Version 4 (TCP/IPv4)" option.
- ⑥ In the TCP/IPv4 properties window that appears, select "Use the following IP address", then enter the new IP address, subnet mask, and default gateway you want to set.
- ⑦ After confirming the input, click the "OK" button to save the changes and close the window.

Once you have completed the above steps, the IP address of your PC will be modified. Please ensure that the newly set IP address is compatible with the network environment and avoid conflicts with other devices.

3. If fail to scan the connected PLC, you can try the following steps: Right-click on the [Double-click to scan Ethernet] option in the device tree. Alternatively, navigate to the [Communications] and select the appropriate network card from the dropdown menu under the [Adaptor] option that is connected to the PLC. Then, retry to scan.

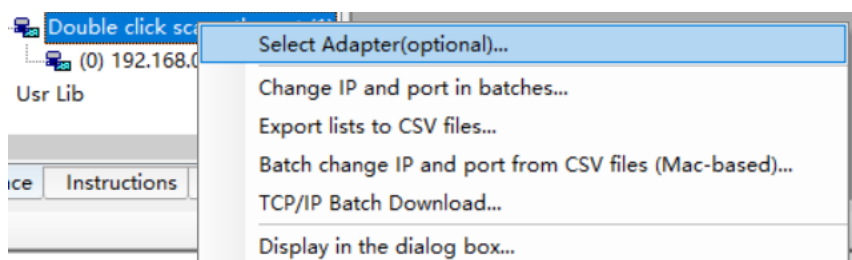

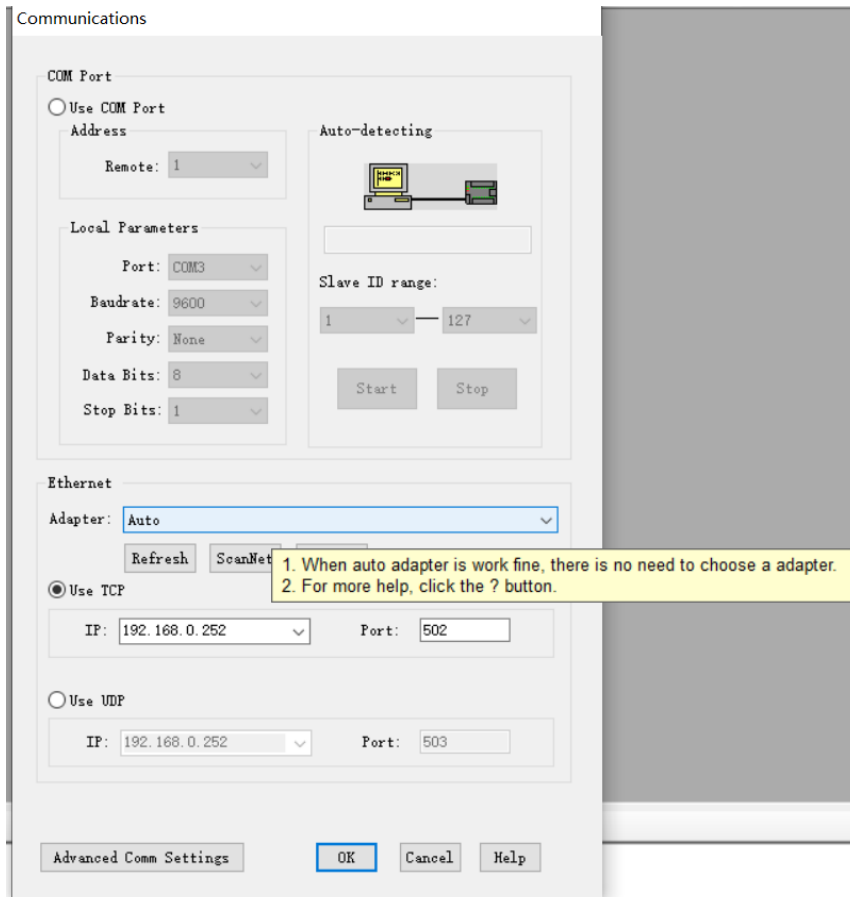

4. Regardless of the method used for device scanning as described above, upon successful scanning, corresponding PLC information will appear:

① After double-clicking [Double click scan ethernet], all connected PLCs in the network will appear under this section in the device tree.

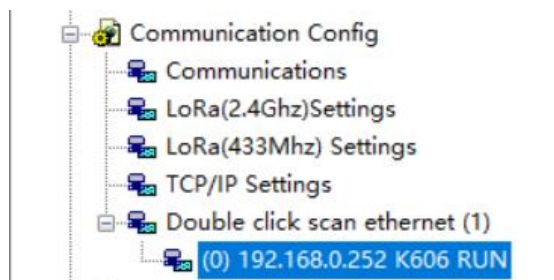

② When clicking [Communications] for scanning, a pop-up window named "Scan all PLCs on the Local area network" will appear, and all connected PLCs in the network will also appear within this pop-up window.

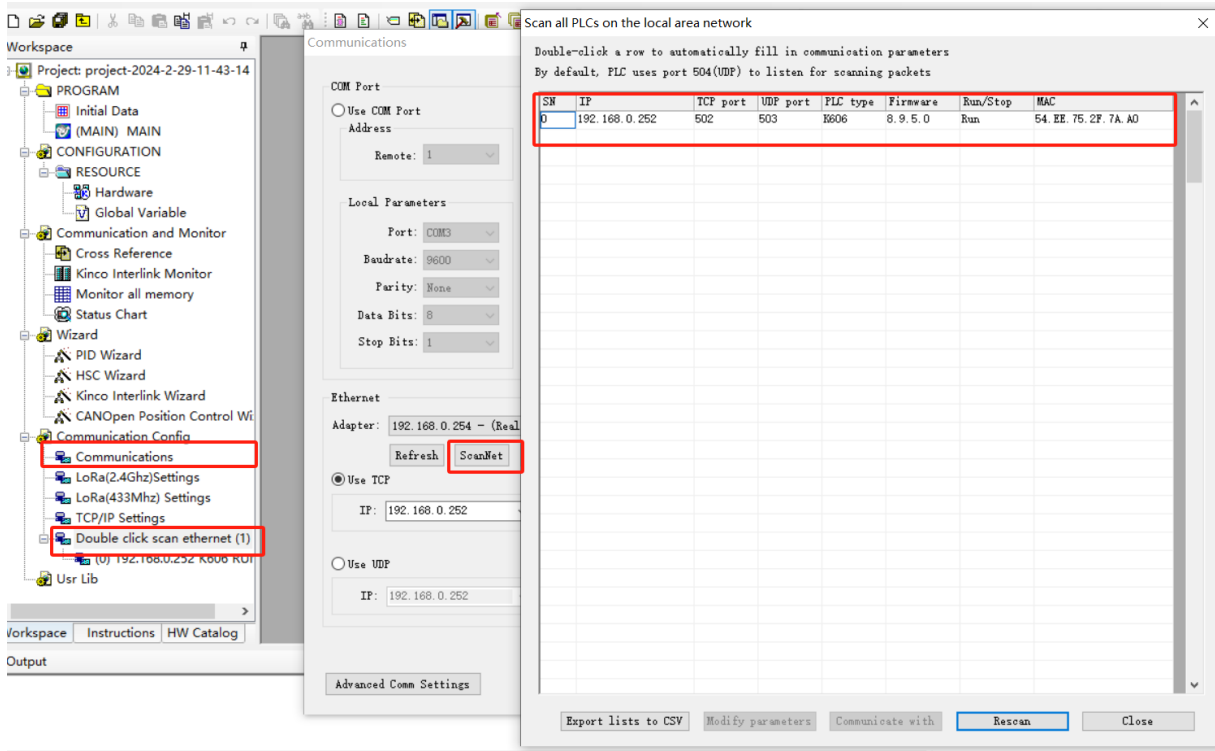

5. Finally, right-click on the scanned devices in the device tree or right-click on the devices in "Scan all PLCs on the Local area network" and click on [Communicate with] from the options that appear. If there are no errors returned, it indicates a successful connection. If the settings in [Communications] are not checked for [Use TCP] or [Use UDP], a warning window will pop up. You can resolve this by setting the communication mode to [Use TCP] or [Use UDP] in [Communications] and then retry.

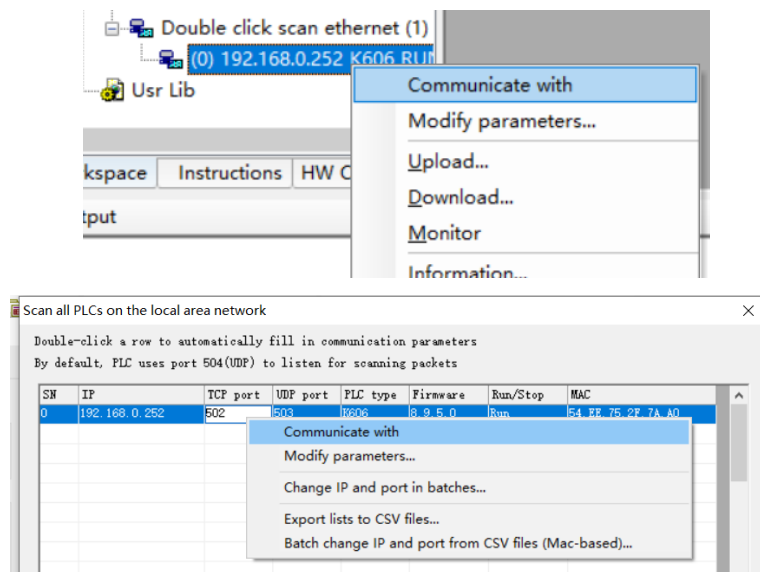



● **Communicate Via RS485**

1. Connect the PC and PLC with an RS485-USB programming cable. The K6-series CPU modules integrates 2 RS485 interfaces, both of which support programming protocol.
2. In this example, the serial port number being used is COM3. Select [Use COM Port] in [Communications] and modify the [Port] to match the actual port number. (please confirm the actual COM port through the PC's Device Manager)

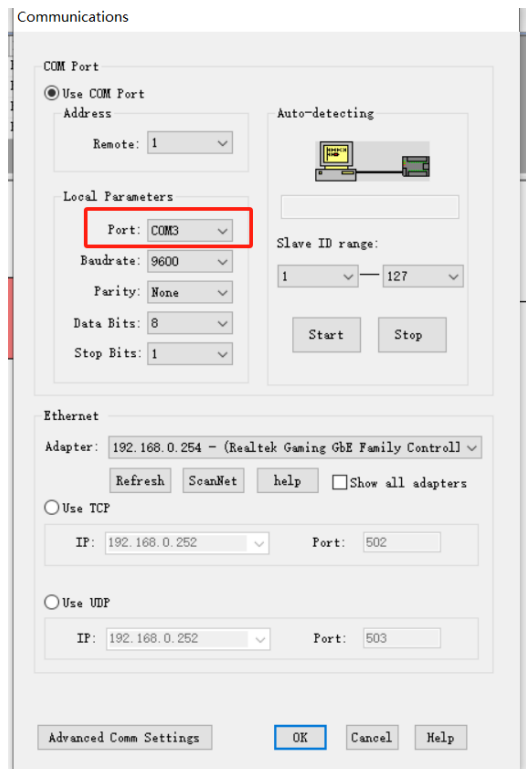

3. Click on [Start] to scan for device. After successful recognition, the [Local Parameters] in KincoBuilder will automatically correspond to the actual parameters. Finally, click "OK" to complete the connection.

Communications

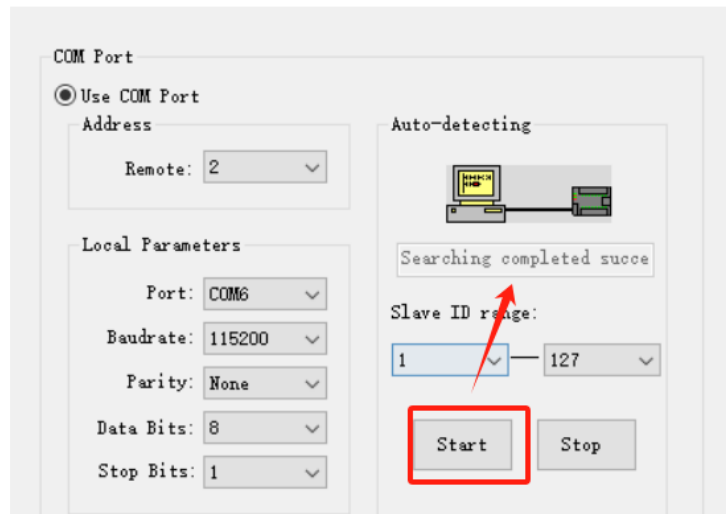

6.6.2 Program Upload/Download

1. Program Upload

- KincoBuilder provides two ways to upload the program: [**Upload**] and [**Upload (breakpoint resume)...**]. Breakpoint transfer refers to the ability to resume transmission from the point where it was interrupted or failed during the file transfer process. This way allows file transfers to be completed efficiently even if the network is unstable or the transfer process is interrupted. Therefore, in situations where the network is busy, long-distance transmission, or for large project sizes, it is recommended to use [**Upload (breakpoint resume)...**] for program uploading. On the contrary, [**Upload**] is a one-time transfer, if any error or interruption occurs during the program transfer, KincoBuilder will interrupt the uploading process directly and return an error, requiring the user to re-trigger the upload operation and start the transfer from the beginning.

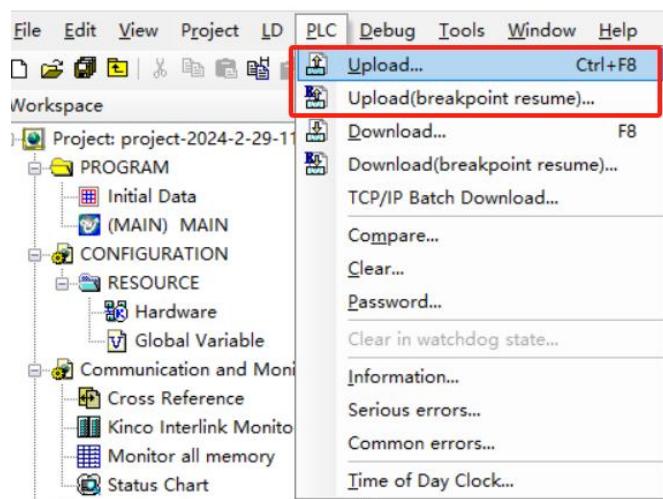

- The process for program uploading is as follows: Before initiating the upload operation, please ensure that communication between the PC and PLC is functioning properly. (refer to [6.6.1 Communication between PC and K6-series PLC](#)). Open the upload window by [PLC] → [Upload] or [Upload(breakpoint resume)...] from the menu bar. Once the upload is complete, a window for selecting the save path will pop-up. Choose the target save path and click OK. After the upload is finished, the uploaded project will automatically open.

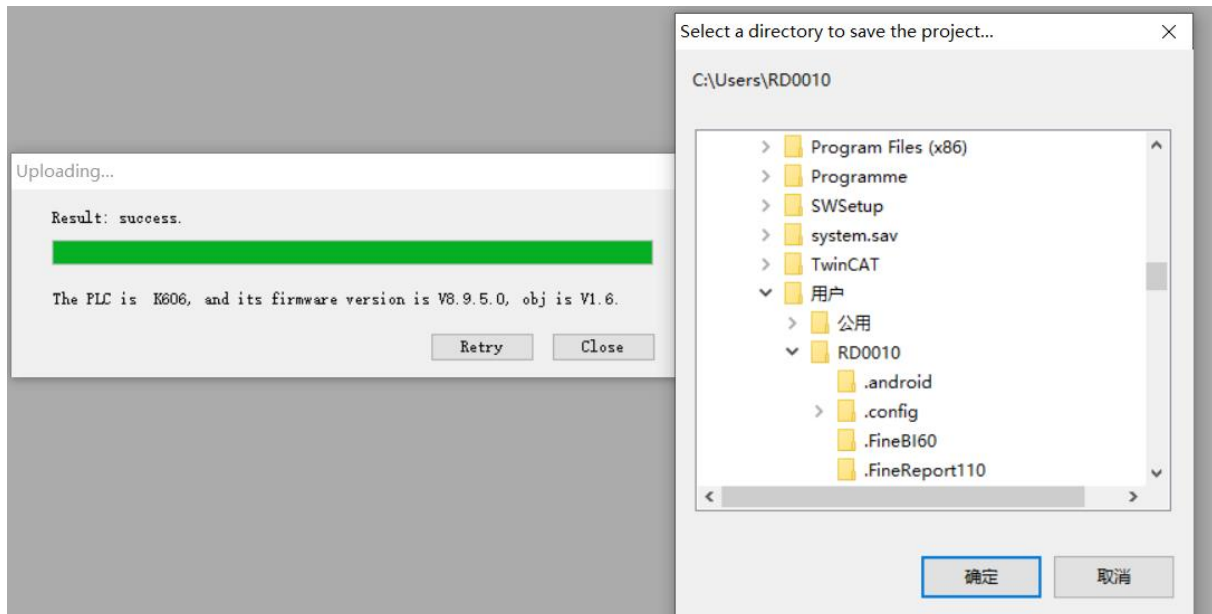

2. Program Download

- KincoBuilder offers two methods of program downloading: [Download] and [Download (breakpoint resume)...]. Similarly (refer to **Program Upload**), when the program download process is frequently interrupted, the network is busy, long-distance transmission is required, or for large project sizes, it is recommended to use [Download (breakpoint resume)...] for downloading programs.

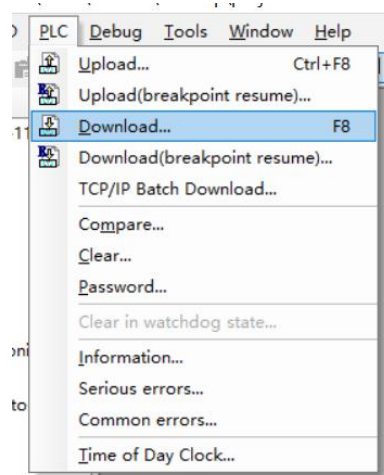

- The process for program downloading is as follows: Before initiating the download operation, please ensure that communication between the PC and PLC is functioning properly(refer to [6.6.1 Communication between PC and K6-series PLC](#)). Open the download window by selecting [PLC] → [Download] from the menu bar or by using the shortcut key [F8]. Prior to the start of the download process, KincoBuilder will automatically compile the current project, and relevant information will be displayed in the [Compile] window. After successful compiling, clicking [Download] key in [Download project], then will trigger the download process normally. Upon completion of the download, there will be a prompt in the [Output] window, displaying information such as the software version and model of the current device.

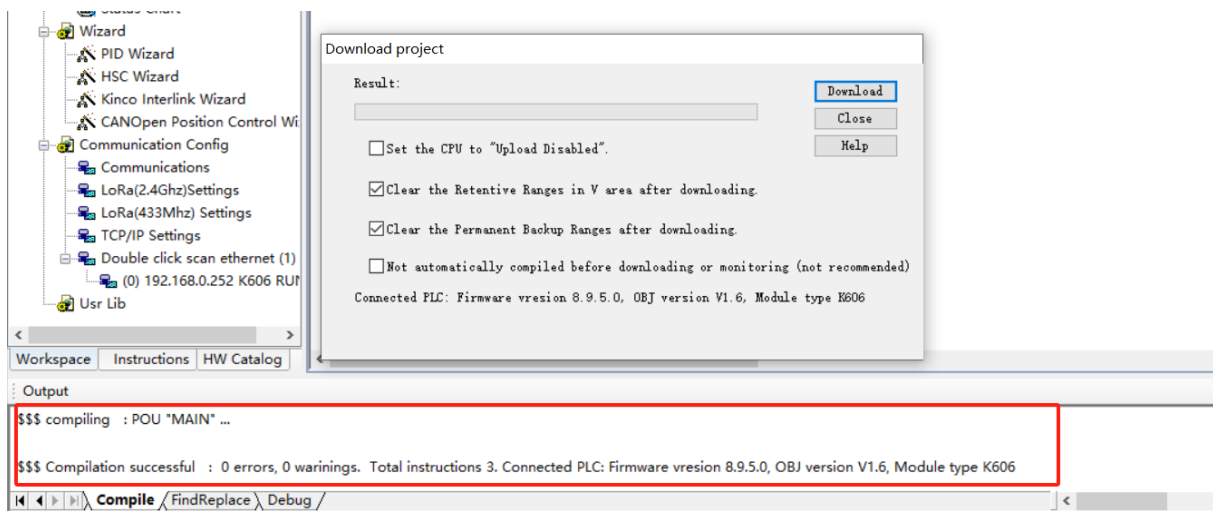

Option	Explanations
Set the CPU to "Upload Disabled"	Enabling this option will encrypt and store all user programs in the PLC, and "Upload program" will not be supported. Please be careful when enabling this option and take care of program backup.
Clear the Retentive Ranges in V area after downloading	Enabling this option will clear all data in the V-area and C-area of the Data Maintain after program downloading, while disabling it will have no effect.
Clear the Permanent Backup Ranges after downloading	Enabling this option will clear all data in the Permanent Storage after program downloading, while disabling it will have no effect.
Not automatically compiled before downloading or monitoring(not recommend)	Enabling this option will prevent automatic compilation after clicking "Download" or "Toggles Monitroing Mode(F6)" in this session, which may lead to abnormal program execution or monitoring. This may not be conducive to program troubleshooting and monitoring. Please be careful when enabling this option. This setting is only valid for the current session and needs to be re-enabled after restarting KincoBuilder.

6.7 Error Message and Solution

6.7.1 Error Message in KincoBuilder

Before viewing the PLC error message, please make sure that the PLC and PC are communicating normally, otherwise, please refer to ["Conneted to PC"](#) for connection.

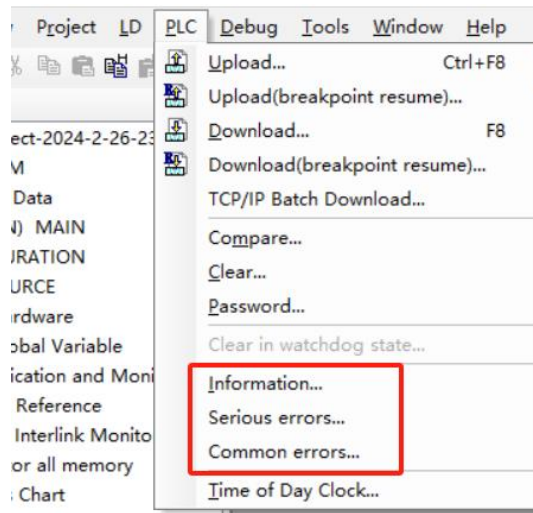

6.7.2 Common Error

The error message consists of an error code and a description of the message. The following are common error codes encountered by users during initial use, along with their corresponding solutions.

Error Code	Description	Solution
20	The PLC in "Hardware" does not match the actual connected CPU.	This error is generally due to a mismatch between the PLC being used and the PLC configured in KincoBuilder. Please check and correct the settings in the "Hardware" section.
21	There are errors in the "Hardware" configuration for the expansion modules.	This error is caused by a mismatch between the configured expansion-bus configuration and the actual application. Please check if the module adding sequence in the "Hardware" matches the actual connection sequence and if the configured modules match the actual ones.
29	Unknown instructions are detected in the PLC program during power-on.	This error usually due to the firmware version does not match the programming version. When KincoBuilder updates, it may modify certain instructions, and new instructions and features

		<p>require compatible software and firmware. Please check the current KincoBuilder and firmware versions. New software can be obtained from the official Kinco website, while PLC firmware can be obtained by contacting Kinco's technical support or local service centers.</p>
--	--	--

If you need more detailed explanations of error codes, please open the [Online Help](#) or download the "Kinco-K Series Application Manual" from the official website (<https://www.kinco.cn/download/plc25.html>) for self-assistance and reference.

6.8 Firmware Update

KincoBuilder comes with a firmware update program, users can connect the PLC through the KincoBuilder to update the firmware of the PLC: [Tools] → [PLC Firmware Upgrade(Common)...].

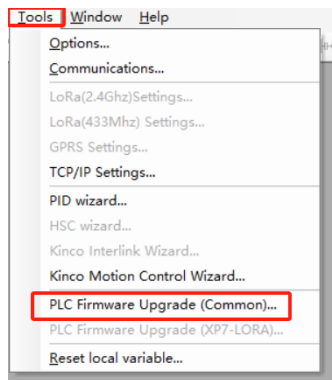

Open the firmware update program will pop up the update operation prompt page, as shown in the following figure:

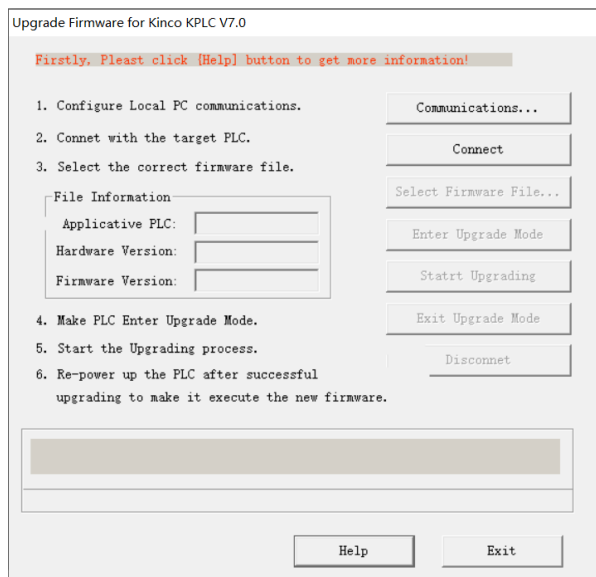

The method of entering the system update mode varies depending on the PLC product.

Before starting the firmware update, read the [Help] instructions on the [Upgrade Firmware for Kinco KPLC] carefully. The specific update procedures are listed on the left side of the pop-up window. Please follow the instructions according to your model.

×

Descriptions for Upgrade Firmware

- 1、For K5 series, you can upgrade firmware through PORT0 (RS232).
Put the [RUN/STOP] switch to "STOP" position, then PLC enters STOP mode.
- 2、For K2 series, you can upgrade firmware through MicroUSB port.
Put the [RUN/STOP] switch to "STOP" position, then PLC enters STOP mode.
- 3、For K5 series, you can upgrade firmware through PORT0 (RS232) or PORT1 (RS485).
Put all the bits of the DIP switch except CAN terminal resistance bits to "OFF" position,
then PLC enters STOP mode.
- 4、For KW and KM series, you can upgrade firmware through MicroUSB, PORT0 (RS232) or PORT1 (RS485).
PLC doesn't need to enter STOP mode.
- 5、For K6 series, you can upgrade firmware through Ethernet or PORT1 (RS485).
PLC doesn't need to enter STOP mode.
- 6、For MK series, you can upgrade firmware through USB or PORT1 (RS485).
PLC doesn't need to enter STOP mode.

PLC has two modes: Normal Operation mode and Firmware Upgrade mode.
You can upgrade a PLC's firmware only when it is in the Firmware Upgrade mode.

The steps for Upgrade Firmware are as following:

1. Connect the PLC with PC using communication cable, and then power on to make PLC into RUN mode.
Note: The PLC with USB can be supplied through the USB cable, so it needs no additional DC24V power.
2. Configure Local PC communications for upgrading in [Communications...] dialog.
3. (Optional) Make the PLC to enter STOP mode.
Note: KM, HP, and KW series don't need to STOP.
4. Click [Connect] button to build a connection with the target PLC.
5. Click [Select Firmware File...] button, and select a firmware file to open it.
If the file is correct, its suitable PLC type and Hardware version will be displayed in [File information],
also the firmware version included in this file will be displayed.
6. Click [Enter Upgrade Mode] button, and after delaying about 2s, PLC enters Firmware Upgrade mode.
In the Firmware Upgrade mode, the "RUN" LED flickers quickly.
Click [Exit Upgrade Mode] button, plc can exit upgrade mode.
7. Click [Start Upgrading] button to start the upgrade process.
Upgrading operations include Erasing FLASH, Writing to FLASH, Verifying FLASH, and so on.
8. You need to re-power up the PLC after successful upgrading, and the PLC will execute the new firmware.

The steps for updating the firmware of K6 series PLC using the Ethernet port are as follows:

1. Connect the PLC to the PC via Ethernet interface and power up the PLC.
2. Click on [Communications...] to configure the communication parameters.

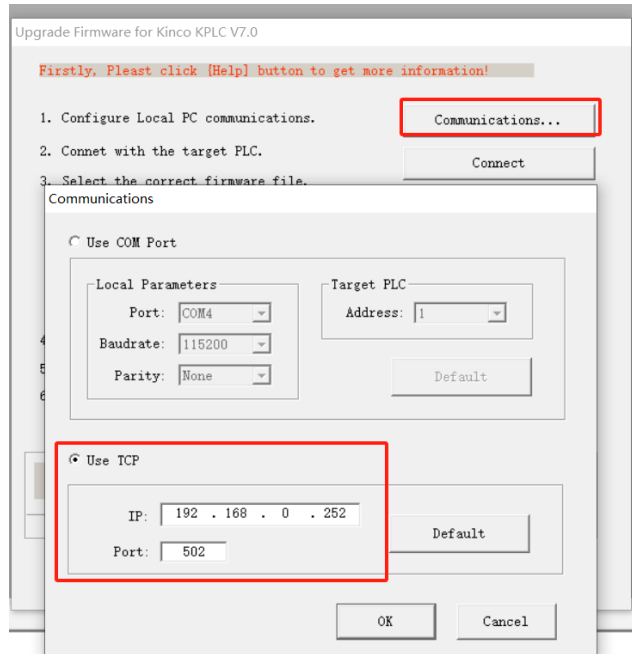

3. Click on [Select Firmware File...] and choose the target file and then click "OK".

ps: If the selected file is valid, the "File Information" section will display the applicable PLC mode, hardware version, and firmware version.

4. Click on the [Enter Upgrade Mode]. After about 2 seconds, the "Run" light on the PLC panel will flash rapidly, indicating that the PLC has successfully entered system update mode.

5. Click on the [Start Upgrading] to initiate the system update for the PLC. The update process includes erasing the PLC's FLASH data, writing new data, and verifying the written data. The "Operation Information Prompt" at the bottom of the window will display the ongoing operations and progress. If there are any errors, they will be listed along with the error reasons.

6. After receiving a successful update prompt, restart the PLC to ensure it automatically loads and runs the new firmware program.

Solution for Firmware Update Failure:

If encounter an error message indicating a failed update during the process, and the PLC's [Run] light is continuously flashing, then try repeatedly clicking on [Start Upgrading].

If, after restarting the PLC following a failed update, the PLC can be connected but cannot enter the update mode, try power off the PLC for a while before update again.

If firmware update still cannot be performed, please check the [Run] light, battery level, and firmware version, and then contact Kinco Technology Support or local agents for assistance.

7 Services and Support

7.1 Services

- Technical Support Hotline

If you have any questions about product selection or usage, you can seek technical support by calling our technical support hotline: 400-700-5281.

- Agents and Offices

If you have any questions about the products described in this manual, please contact the local offices and agents of Kinco. For information regarding user training and other matters, please visit the company's website or contact local agents for training plans.

7.2 Contact Us

Kinco(Shanghai) Automation Co., Ltd.

Address: Building 3, No. 26 Qiuyue Road, Zhangjiang High-Tech Park, Shanghai (201203)

Tel: 86-21-68798588

Fax: 86-21-68797688

Email: sales@kinco.cn

Kinco Electric Co., Ltd. Shenzhen Branch

Address: 3rd Floor, Building 1, Yizhongli Industrial Park, No. 6 Langshan 1st Road, North District, High-Tech Park, Nanshan District, Shenzhen (518057)

Tel: 86-755-26585555 (12 lines)

Fax: 86-755-26616372

Email: sales@kinco.cn

8 Appendix

8.1 Fast Selection List

Model	Description
CPU	
K606-24DT	Powered by DC 24V, DI 14*DC24V(PNP/NPN), DO 10*DC24V(PNP) 2*RS485, 1*Ethernet Support a maximum of 1 BD expansion module and 14 bus-expansion modules.
K606-24AT	Powered by AC100-240V, DI 14*DC24V(PNP/NPN), DO 10*DC24V(PNP) 2*RS485, 1*Ethernet Support a maximum of 1 BD expansion module and 14 bus-expansion modules.
K606-24DR	Powered by DC24V, DI 14*DC24V(PNP/NPN), DO 10*Relay 2*RS485, 1*Ethernet Support a maximum of 1 BD expansion module and 14 bus-expansion modules.
K606-24AR	Powered by AC100-240V, DI 14*DC24V(PNP/NPN), DO 10*Relay 2*RS485, 1*Ethernet Support a maximum of 1 BD expansion module and 14 bus-expansion modules.
K606EA-30DT	Powered by DC24V, DI 14*DC24V(PNP/NPN), DO 10*DC24V(PNP), AI 4*IV, AO 2*IV 2*RS485, 1*Ethernet Support a maximum of 2 BD expansion modules and 14 bus-expansion modules.
K606EA-30AT	Powered by AC100-240V, DI 14*DC24V(PNP/NPN), DO 10*DC24V(PNP); AI 4*IV, AO 2*IV 2*RS485, 1*Ethernet Support a maximum of 2 BD expansion modules and 14 bus-expansion modules.
K608-40DT	Powered by DC24V, DI 24*DC24V(PNP/NPN), DO 16*DC24V(PNP) 2*RS485, 1*Ethernet Support a maximum of 2 BD expansion modules and 14 bus-expansion modules.
K608-40AT	Powered by AC100-240V, DI 24*DC24V(PNP/NPN), DO 16*DC24V(PNP) 2*RS485, 1*Ethernet Support a maximum of 2 BD expansion modules and 14 bus-expansion modules.
K608-40DR	Powered by DC24V, DI 24*DC24V(PNP/NPN), DO 16*Relay 2*RS485, 1*Ethernet

	Support a maximum of 2 BD expansion modules and 14 bus-expansion modules.
K608-40AR	Powered by AC100-240V, DI 24*DC24V(PNP/NPN), DO 16*Relay 2*RS485, 1*Ethernet Support a maximum of 2 BD expansion modules and 14 bus-expansion modules.
Expansion Modules	
K621-08DX	DI 8*DC24V (PNP/NPN)
K621-16DX	DI 16*DC24V (PNP/NPN)
K622-08XR	DO 8*Relay
K622-16XR	DO 16*Relay
K622-08DT	DO 8*DC24V(PNP)
K622-16DT	DO 16*DC24V(PNP)
K623-16DR	DI 8*DC24V(PNP/NPN), DO 8*Relay
K623-08DR	DI 4*DC24V(PNP/NPN), DO 4*Relay
K623-16DT	DI 8*DC24V(PNP/NPN), DO 8*DC24V(PNP)
K623-08DT	DI 4*DC24V(PNP/NPN), DO 4*DC24V(PNP)
K631-04IV	4*AI, 4-20mA/1-5V/0-20mA/0-10V
K631-04RD	4*RD, Pt100, Pt1000, Cu50, Resistor
K631-04TC	4*TC, thermocouple cold junction compensation (CJC) options include internal and external compensation. Supported thermocouple types include J, K, E, S, and T.
K632-02IV	2*AO, 4-20mA/1-5V/0-20mA/0-10V
K633-04IV	2*AI, 4-20mA/1-5V/0-20mA/0-10V 2*AO, 4-20mA/1-5V/0-20mA/0-10V
BD Expansion Module	
KB6-CAN	1*CAN(CAN2)
KB6-2COM	1*RS232(PORT0), 1*RS485(PORT3)
KB6-4DI	DI 4*DC24V(PNP/NPN)
KB6-4DO	DO 4*DC24V(PNP)
Power Supply Module	
K680	Powered by AC85~265V; Rated output current: 5V 1A/24V 250mA

8.2 Output Power Supply

K6 series CPUs are equipped with a standard DC24V output, which can supply power to I/O channels and some field devices. However, it is crucial to ensure that the total power consumption does not exceed the rated capacity of this output power supply. Otherwise, an additional DC24V power supply needs to be configured for the system. If both the standard DC24V output and an external DC24V power supply are used simultaneously, it's important to avoid connecting different power sources in parallel. Therefore, it is recommended to connect the common terminals of different power sources to obtain a consistent voltage reference.

The table below lists the maximum output current values of the DC24V output power supply (VO+, VO-) on various CPU modules.

CPU606	300 mA
CPU606EA, CPU608	AC-powered: 500mA DC-powered: 300mA

8.3 Expansion-bus Power Consumption Calculation

When configuring a PLC system, it's essential to consider whether the power supply provided by the CPU module to the expansion modules, such as the +5V working power and +24V relay coil driving power, can meet the requirements of the system's expansion modules. If the system configuration exceeds the power supply capacity of the CPU, users can either choose to configure multiple CPU modules to meet the system requirements or supplement the expansion power by adding PS680 expansion power supplies.

The table below lists the power capacity of each CPU module and the PS680 expansion power supply module, as well as the current consumption values of various expansion modules.

Power Capacity		
	+5V	+24V
CPU606 CPU606EA CPU608	1500mA	360mA
PS680	1000mA	250mA
Power Consumption of Module		
	Current Loss with External DC24V Supply	Current Loss When Powered by the Expansion-bus

	(Typical at Full Load)	(Maximum Value)	
		+5V	+24V
K621-08DX	-	180mA	-
K621-16DX	-	210mA	-
K622-08DT	-	200mA	-
K622-08XR	-	180mA	60mA
K622-16DT	-	240mA	-
K622-16XR	-	210mA	120mA
K623-08DT	-	200mA	-
K623-08DR	-	180mA	30mA
K623-16DT	-	240mA	-
K623-16DR	-	210mA	60mA
K631-04IV	10mA	172mA	-
K631-04RD	10mA	172mA	-
K631-04TC	10mA	172mA	-
K632-02IV	10mA	160mA	-
K633-04IV	10mA	166mA	-

8.4 Input Power for the CPU

The table below lists the input power data for various CPU modules under different conditions:

Max Power: The input power required when all components of the CPU module are fully loaded (including full load of DC24V output power supply and expansion power supply).

Max Power per Unit: The input power required when the CPU is not connected to expansion modules, but all other components are fully loaded (including full load of DC24V output power supply).

Typical Power per Unit: The input power required when the CPU is not connected to expansion modules, the DC24V output power supply is unloaded, but all other components are operating normally.

		Max Power (W)	Max Power/Unit (W)	Typical Power/Unit (W)
CPU606	AC-powered	40.0	22.5	3.9
	DC-powered	24.0	10.5	3.0

CPU606EA	AC-powered	40.0	22.8	4.0
	DC-powered	24.0	12	3.5
CPU608	AC-powered	40.0	23.2	4.2
	DC-powered	24.0	11.2	3.0

8.5 Example of PLC System Selection & Power Calculation

8.5.1 General Guidelines for PLC System Selection

System selection relies more on the customer's scene demands, ranging from processes to applications, including considerations such as control processes, equipment or machinery, and aspects like real-time performance, accuracy, and reliability. It's essential to choose a PLC with corresponding processing capability, considering factors like data capacity, program capacity, and memory space.

Based on on-site requirements, determine the quantity and type of digital inputs, digital outputs, analog inputs, analog outputs, and other I/O points needed. For standalone or production line equipment that requires connections to upstream and downstream devices, communication considerations are crucial to effectively connect with other devices, sensors, actuators, or upper-level control systems.

Special requirements regarding environmental conditions (temperature, humidity, vibration, noise), safety, installation space, and installation methods necessitate consideration of factors such as PLC protection level, EMC level, temperature rating, redundancy features, PLC volume, and installation methods.

When making system selections, it's crucial to comprehensively consider these factors to ensure the chosen PLC can reliably meet control requirements. After completing the selection process, power consumption calculations for the selected system are necessary to form a closed loop between selection and actual application. For further support and professional advice, please contact Kinco's sales customer service or authorized distributors.

8.5.2 Example of System Selection

Assuming we need to design a control system for an automated production line, controlling a packaging machine and auxiliary functions before and after the entire line. Below is a simplified example of PLC system selection and power calculation:

1. Process Requirements:

- Conveyor control: Controls the conveyor belt for products entering the packaging area from the production line.
- Positioning: Uses sensors to detect product positions, ensuring accurate entry into the packaging stage.
- Packaging: Controls the packaging machine arm to wrap packaging material around the product.

- Sealing: Controls the sealing mechanism to ensure proper closure of packaging bags with adjustable sealing temperature.
- Output conveyor: Controls the conveyor belt for products leaving the packaging area.

2. Control Requirements:

- 52 digital inputs (for sensor signals and other controls).
- 40 digital outputs (relay outputs: valves, sealing control, machine arm, etc.).
- 1 analog output (4~20mA, controls sealing mechanism temperature).
- 2 analog inputs (4~20mA).
- 2 RS485 communication requirements (communication with upper-level HMI, conveyor frequency converter).

3. Other Requirements:

- In this selection example, we are ignoring the details of other requirements.

4. Selection scheme

	Model	Number	DI	DO (Relay)	AI	AO	RS485	Summary
Option A (K606)	K606-24DR	1	14	10	0	0	2	DI:54 DO(Relay):42 AI:2 AO:2 RS485:2
	K623-16DR	2	8	8	0	0	0	
	K621-16DX	1	16	0	0	0	0	
	K621-08DX	1	8	0	0	0	0	
	K622-16XR	1	0	16	0	0	0	
	K633-04IV	1	0	0	2	2	0	
Option B (K608)	K608-40DR	1	24	16	0	0	2	DI:56 DO(Relay):40 AI:2 AO:2 RS485:2
	K622-16XR	1	0	16	0	0	0	
	K623-16DR	1	8	8	0	0	0	
	K621-16DX	1	16	0	0	0	0	
	K621-08DX	1	8	0	0	0	0	
	K633-04IV	1	0	0	2	2	0	

As shown in the table above, based on the requirements, there are two options available. Option A has 2 remaining digital inputs (DI) and 2 remaining digital outputs (DO), while Option B has 2 remaining digital inputs (DI) but no remaining digital outputs (DO). Ignoring other factors and solely considering the expandability of the system, Option A is selected as the preferred choice for this example to accommodate potential future changes and evolving needs.

5. Power Calculation

Here we'll perform a power consumption calculation for Option A as an example.

	Model	Number	E-Bus Consumption (+5V,mA)	E-Bus Consumption (+24V,mA)	External Consumption (DC24V,mA)
Option A (K606)	K606-24DR	1	-	-	1000
	K623-16DR	2	420	120	-
	K621-16DX	1	210	-	-
	K621-08DX	1	180	-	-
	K622-16XR	1	210	120	-
	K633-04IV	1	166	-	10
Total(E-bus +5V)		-	1186	-	-
Total(E-bus +24V)		-	-	240	-
Total(External DC24V)		-	-	-	1010

As shown in the table above, the CPU606's expansion bus is required to provide a current consumption of 1186mA for +5V and 240mA for +24V power supply. According to Appendix [8.3 Expansion-bus Power Consumption Calculation](#), the maximum current that the CPU606 expansion bus can provide is 1500mA for +5V and 360mA for +24V, providing a 20% power margin even under full system load. The K633-04IV module requires an external DC24V power supply to drive external circuits, which can be optionally sourced from the CPU606's built-in DC24V output power. When using an external DC24V power input for the CPU system, please ensure that the current of the external DC power supply is 1A or more.